



CIVIL AVIATION ADVISORY PUBLICATION

CAAP 72

AIRCRAFT LANDING AREAS: PRIVATE USE (NOT AIR SERVICE)

***INFORMATION AND GUIDANCE MATERIAL FOR LANDING AREAS WHICH ARE NOT FOR
PUBLIC TRANSPORT USE AND DO NOT HAVE INSTRUMENT RUNWAYS***

1 CONTENTS

- Chapter 1 – Introduction 4
 - 2 General 4
 - 3 Implementation of Safety Oversight At Aircraft Landing Areas..... 4
 - 4 Purpose..... 4
 - 5 Status of this CAAP 5
 - 6 Applicability 5
 - 7 References..... 5
 - 8 Guidance..... 5
 - 9 Policy..... 5
 - 10 Definitions 6
 - 11 Abbreviations 9
- Chapter 2 – Process For Gaining a Certificate or Acceptance..... 10
 - 1 “Aerodrome Certificate” or “Aircraft Landing Area Acceptance”? 10
 - 2 Application for An Aircraft Landing Area Acceptance 10
 - 3 Service Fees 11
 - 4 Location of Aircraft Landing Areas 11
 - 4 Naming of Aircraft Landing Areas..... 11
 - 5 Aircraft Landing Area Data..... 12
 - 6 Aerodrome Reference Code 12
 - 7 Aviation Security 12
 - 8 Aeronautical Information Service..... 12
- Chapter 3 – Physical Characteristics 14
 - 1. General 14
 - 2 Declared Distances..... 14
 - 3 Runway 15
 - 4 Runway Strip 15
 - 5 Taxiways 16
 - 6 Holding Bays, Runway Holding Positions 17
 - 7 Aprons / Aircraft Parking 17
- Chapter 4 – Obstacle Restriction and Removal 19
 - 1 Introduction..... 19
 - 2 Obstacle Limitation Surfaces 19
 - 3 Safeguarding of Aircraft Landing Areas..... 22
 - 4 Obstacle Restriction and Removal 23

Chapter 5 – Visual Aids For Navigation.....	25
1 Indicators, Signals and Markings	25
2 Markings.....	25
3 Aeronautical Lights.....	27
4 Signs.....	27
5 Wind Direction Indicator	29
6 Signal Area.....	29
Chapter 6 – Aeroplane Fire Team	32
1 Principle Objective	32
2 Extinguishing Agents.....	33
3 Response Time Objective	36
4 Minimum Number Of Aeroplane Fire Team Personnel	36
5 Training and Development	36
Chapter 7 – Fuel Management	38
1 Introduction.....	38
2 Aeroplane refuelling	38
3 Procedures For Safe Handling and Storage of Fuel	39
4 Risk Evaluation: Fire Risk.....	39
5 Risk Evaluation: Portable Electronic Devices (PED)	41
6 Detection and Prevention of Fuel Contamination.....	42
7 Technical Specifications.....	45
Chapter 8 – Aircraft Landing Area Operations	46
1. Aerodrome Manual.....	46
2 Safety Management Systems (SMS)	46
3 Mandatory Reporting	47
4 Wildlife Hazard Management.....	47
5 Foreign Object Debris (FOD).....	48
6 Low Visibility Operations	48
7 Night Use	48
Appendix A: Aerodrome Reference Code & Aerodrome Data	49
Appendix B: Requirements for Aerodrome Certification or Aircraft Landing Area Acceptance	50

CHAPTER 1 – INTRODUCTION

2 GENERAL

2.1 The purpose of this CAAP is to provide guidance and policy information to all operators of UAE aerodromes, which are not intended for Air Service operations and have non-instrument runways, (excluding areas used solely for Light Sport Aircraft). It is proposed that this CAAP will be incorporated into CAR Part IX (Aerodromes) and will form GCAA regulation. This CAAP will enter into force on 30th June 2014.

2.2 Throughout this document reference has been made to CAR Part IX (Aerodromes) where it is considered that additional information would support this guidance material.

2.3 By following the guidance described in this publication and **CAAP 30** (The Issue and Verification of an Aerodrome Certificate – including Aircraft Landing Area Acceptance), and on successful completion of processes listed, an **“Aircraft Landing Area Acceptance”** will be provided. (Refer to Appendix C for guidance on operational status).

2.4 For the provision of ***Air Service and other aerodromes which provide facilities for operations using instrument approach or departure procedures***, then reference shall be made to **CAR Part IX** and guidance provided in **CAAP 30** for the application of an **Aerodrome Certificate**.

2.5 For aerodromes which are listed as not Air Service operations (with non-instrument runways) and issued with an Aircraft Landing Area Acceptance, who later choose to extend operations to an Air Service or provide operations using instrument approach or departure procedures, then applicants shall re-apply for an Aerodrome Certificate, following the guidance in CAAP 30.

2.6 Before granting an Aircraft Landing Area Acceptance (or an Aerodrome Certificate), the Authority must be satisfied that payment of the appropriate fees has been received.

2.7 This CAAP should be used in conjunction with CAR Part IX, X, XI and other GCAA publications, relevant to aerodrome operations.

3 IMPLEMENTATION OF SAFETY OVERSIGHT AT AIRCRAFT LANDING AREAS

3.1 It is intended that implementation will be a phased approach, with new construction and operations conforming to this CAAP from the implementation date.

3.2 Compliance with this CAAP at established Aircraft Landing Areas will be phased over a set period in agreement with the GCAA.

3.3 It will be a requirement to hold a landing area acceptance in order to operate or to continue operations.

4 PURPOSE

The information in this publication will ensure compliance with the UAE Civil Aviation Law and Civil Aviation Regulations and conformance with the international standards of ICAO Annex 14,

Volume I. Civil Aviation Regulation, Part III (General Regulations: Aerodromes), Chapter 5 states that: “An aircraft shall not land at, or take-off from, any place unless; the place is suitable for use as an aerodrome for the purposes of the landing and taking-off of aircraft in safety, having regard to all circumstances, including the prevailing weather conditions”. The guidance material set out in this CAAP indicates the minimum requirements to determine the suitability of an aerodrome and its continued use.

5 STATUS OF THIS CAAP

This is the first issue of CAAP 72. This Issue is based on NPA 10-2013. There have been no comments received against the NPA.

6 APPLICABILITY

This CAAP is applicable to all operators or prospective operators, which do not offer Air Service operations and do not operate with instrument runways.

7 REFERENCES

- a) CAR Part IX (Aerodromes)
- b) CAR Part X (Safety Management Requirements)
- c) CAR Part XI (Aerodrome Emergency Services, Facilities and Equipment)
- d) CAAP 22 (Safety Incident Reporting)
- e) CAAP 30 (The Issue and Verification of an Aerodrome Certificate – including Aircraft Landing Area Acceptance)
- f) CAAP 35 (Inspecting and Testing of Rescue and Fire-Fighting Equipment)
- g) CAAP 36 (Runway and Movement Area Inspections)
- h) CAAP 43 (Foreign Object Debris – FOD)
- i) CAAP 50 (Safety Management Systems)
- j) CAAP 57 (Voluntary Occurrence Reporting System)
- k) CAAP 70 (Heliports: Air Service and Non-Public Transport Use)
- l) ICAO Annex 15 (Aeronautical Information Services)

8 GUIDANCE

For guidance on points that are not covered within this publication, advice should be sought from the Aviation Safety Affairs Sector, GCAA; email: ana@gcaa.gov.ae

9 POLICY

9.1 The GCAA may accept landing areas for operational use once the acceptance criteria have been met; however the responsibility for the maintenance and condition of the landing area, the facilities and for obstacle control, remains with the Aircraft Land Area Acceptance Holder.

10 DEFINITIONS

Aerodrome	A defined area on land or water (including any buildings, installations, and equipment) intended to be used either wholly or in part for the arrival, departure and surface movement of aircraft.
Aerodrome Certificate	A Certificate issued by the Authority under Civil Aviation Regulation Part IX for the operation of an aerodrome. (Air Service and other aerodromes which provide operations using instrument approach or departure procedures).
Aerodrome Facilities and Equipment	Facilities and equipment, inside or outside the boundaries of the aerodrome (or heliport), that are constructed or installed, operated and maintained for the arrival, departure and surface movement of aircraft.
Aerodrome Manual	The Manual that forms part of the application for an Operational Acceptance, including any amendments thereto accepted by the Authority.
Aircraft	Any machine that can derive support in the atmosphere from the reactions of the air other than the reactions of the air against the earth's surface.
Aircraft Landing Area Acceptance	A landing area for the operation of private use (not Air Service) and non-instrument runways. (Excluding areas used solely for Light Sport Aircraft).
Aircraft Landing Area Operator	In relation to an Aircraft Landing Area Acceptance, the Aircraft Landing Area Acceptance holder.
Aircraft Landing Area Project Plan	A comprehensive plan detailing as a minimum: <ul style="list-style-type: none"> a) timescales and milestones with reference to meeting requirements and guidance provided in CAAP 72; for example: Aerodromes, Aerodrome Emergency Services (AES), Air Navigation Services (ANS); and b) a detailed compliance matrix, demonstrating compliance with GCAA regulations, detailing physical characteristics, appropriate to the scope and scale of the proposed operations.
Air Service	An air service operation open to the public and performed by an aircraft for the public transport of passengers, mail or cargo for remuneration or hire.
Approved by the Authority	Documented by the Authority as suitable for the purpose intended.
Authority	The General Civil Aviation Authority of the United Arab Emirates is the competent body responsible for the safety regulation of Civil Aviation.

Certified Aerodrome	An aerodrome whose operator has been granted an Aerodrome Certificate by the authority under applicable regulations for the operation of an aerodrome. (Air Service and other aerodromes which provide operations using instrument approach or departure procedures).
Commercial Air Transport Operation	An aircraft operation involving the transport of passengers, cargo or mail for remuneration or hire.
Declared Distances	<ul style="list-style-type: none"> a) Take-off run available (TORA). The length of runway declared available and suitable for the ground run of an aeroplane taking off. b) Take-off distance available (TODA). The length of the take-off run available plus the length of the clearway, if provided. c) Accelerate-stop distance available (ASDA). The length of the take-off run available plus the length of the stopway, if provided. d) Landing distance available (LDA). The length of runway which is declared available and suitable for the ground run of an aeroplane landing.
GCAA Inspector	An Inspector from any discipline within the GCAA, dependent upon discipline being inspected or audited.
Grading	Means levelling of the ground surface to meet the applicable slope requirements and so prepared or constructed as to minimise hazards arising from differences in load bearing capacity to aircraft which a runway or taxiway is intended to serve, in the event of an aircraft excursion off the runway or taxiway.
Manoeuvring area	That part of an aerodrome to be used for the take-off, landing and taxiing of aircraft, excluding aprons.
Movement area	That part of an aerodrome to be used for the take-off, landing and taxiing of aircraft, consisting of the manoeuvring area and the apron(s).
Private Operator	Private operator means a person, organisation or enterprise engaged in the carriage of persons or cargo not for hire or reward.
Runway end safety area (RESA)	An area symmetrical about the extended runway centre line and adjacent to the end of the strip primarily intended to reduce the risk of damage to an aeroplane undershooting or overrunning the runway.

Runway Strip	<p>A defined area including the runway and stopway, if provided, intended:</p> <ul style="list-style-type: none"> a) to reduce the risk of damage to aircraft running off a runway; and b) to protect aircraft flying over it during take-off or landing operations.
Signal Area	<p>An area on an aerodrome used for the display of ground signals.</p>
Taxiway	<p>A defined path on a land aerodrome established for the taxiing of aircraft and intended to provide a link between one part of the aerodrome and another, including:</p> <ul style="list-style-type: none"> a) <i>Aircraft stand taxilane</i>. A portion of an apron designated as a taxiway and intended to provide access to aircraft stands only. b) <i>Apron taxiway</i>. A portion of a taxiway system located on an apron and intended to provide a through taxi-route across the apron. c) <i>Rapid exit taxiway</i>. A taxiway connected to a runway at an acute angle and designed to allow landing aeroplanes to turn off at higher speeds than are achieved on other exit taxiways thereby minimizing runway occupancy times.

11 ABBREVIATIONS

AIP	Aeronautical Information Publication
APAPI	Abbreviated Precision Approach Path Indicator
ARE	An Aerodrome Reference Elevation
ARP	Aerodrome Reference Point
FOD	Foreign Object Debris
ICAO	International Civil Aviation Organisation
PAPI	Precision Approach Path Indicator
PED	Portable Electronic Devices

CHAPTER 2 – PROCESS FOR GAINING A CERTIFICATE OR ACCEPTANCE

1 “AERODROME CERTIFICATE” OR “AIRCRAFT LANDING AREA ACCEPTANCE”?

1.1 Aerodrome Certification:

This applies to aerodromes which are open to public use and which serve Commercial Air Transport¹ offering an Air Service and other aerodromes which provide operations using instrument approach or departure procedures.

Reference shall be made to CAR Part IX and CAAP 30, which refers to the process to be followed to gain an “Aerodrome Certificate”.

1.2 Aircraft Landing Area Acceptance:

This applies to landing areas which are not for Air Service operations and do not have instrument runways, (excluding areas used solely for Light Sport Aircraft).

Reference shall be made to this document and also to CAR Part IX when additional information is required, and to CAAP 30, which refers to the process to be followed to gain an “Aircraft Landing Area Accept”.

The landing area will be listed with the GCAA once it has been determined that all conditions of acceptance process have been met which, for example, shall include compliance with the specification relating to physical characteristics, visual aids and the operation of the landing area.

2 APPLICATION FOR AN AIRCRAFT LANDING AREA ACCEPTANCE

2.1 All Applicants shall be registered to have secure access to the ANA e-Services for Helicopter Landing Area Acceptance available on the GCAA website: www.gcaa.gov.ae. Each Applicant will be required to hold a GCAA ANA e-Service account and complete an initial aerodrome registration form prior to making an application for a Helicopter Landing Area Acceptance.

3.1 The application process requires the submission of the following documents; full details are described in CAAP 30:

- a) Self-Assessment Safety Matrix
- b) Aircraft Landing Area Project Plan
- c) Draft Aerodrome Manual

3.2 An ***Aircraft Landing Area Acceptance*** will only be provided when the GCAA is satisfied that safe operations are in place and supported by an effective safety management system.

3.3 The GCAA retain the right to inspect the landing area at any time. If conditions or operations are found to be unsafe, the GCAA also retain the right to withdraw or suspend an “Aircraft Landing Area Acceptance”.

¹ **Commercial Air Transportation** means an aircraft operation involving the transport of passengers, cargo or mail for remuneration or hire. (Remuneration means to pay for services rendered; reward or payment).

- 3.4 Before granting an **Aircraft Landing Area Acceptance**, the GCAA must be satisfied that:
- a) the applicant and his/her staff have the necessary competence and experience to operate and maintain the heliport properly;
 - b) the Aerodrome Manual (including SMS) prepared for the applicant's Aircraft Landing Area, contains all the relevant information;
 - c) the landing area's facilities, services and equipment are in accordance with the standards and safety objectives specified by the GCAA;
 - d) the landing area's operating procedures make satisfactory provision for the safety of aircraft;
 - e) an acceptable and effective Safety Management System is in place at the Aircraft Landing Area and
 - f) the payment of GCAA Service Fee has been submitted.

3 SERVICE FEES

Holders of an Aircraft Landing Area Acceptance will be subject to the initial and ongoing annual fees.

4 LOCATION OF AIRCRAFT LANDING AREAS

4.1 The GCAA should be the final authority as to the use of an acceptable Aircraft Landing Area. Prior to the acceptance of any landing area, a "no objection" from the applicable relevant authorities or bodies, must be granted to the proposed holder of the Acceptance. For GCAA acceptance, the aerodrome should not be located;

- a) within the area or in such close proximity as to create a hazard to aircraft operating from UAE designated airports, or to those conducting published instrument approach / departure procedures; or
- b) within any area where the density of aircraft movements makes it undesirable; or
- c) where take-off or landing involving flight over a populated area creates an unnecessary hazard.

4.2 Populated Areas - If the proposed Aircraft Landing Area is located near a city, town or populated area or any other area where noise or other environmental considerations make aircraft operations undesirable, the use of such a landing area may be subject to municipal acceptance. It is the responsibility of the operator to ensure that operations do not create noise or unwanted distraction.

4.3 Additional detail for environmental control: siting and location can be found in CAAP 30.

4 NAMING OF AIRCRAFT LANDING AREAS

4.1 In aviation safety terms, the name of an Aircraft Landing Area is directly connected with aeronautical communications and flight safety information. It is therefore important that the Aircraft Landing Area name is representative of its location (the nearest city, town or village) and should not have the potential to be confused with another aerodrome or Aircraft Landing Area.

5 AIRCRAFT LANDING AREA DATA

5.1 Aircraft Landing Area related aeronautical data should be in accordance with the accuracy and integrity requirements as listed in CAR Part IX.

6 AERODROME REFERENCE CODE

6.1 The specifications for the individual runways are related by a two element reference code, (refer to Table 2.1). Use of this code ensures that the facilities and characteristics of a runway are effectively related and match the needs of the aircraft for which the Aircraft Landing Area intends to cater.

6.2 Establishing the Aerodrome Reference Code, also determines the extent of the sloping surfaces of the airspace surrounding each runway that should be kept free of obstacles.

Table 2.1 Aerodrome (Runway) Reference Code

CODE ELEMENT ONE			CODE ELEMENT 2	
Code Number	The Greater of TODA or ASDA	Code Letter	Wing Span	Outer Main Gear Wheel Span
1	Less than 800m	A	Up to but not including 15m	Up to but not including 4.5m
2	800m up to but not including 1200m	B	15m up to but not including 24m	4.5m up to but not including 6m
3	1200m up to but not including 1800m	C	24m up to but not including 36m	6m up to but not including 9m
4	1800m and over	D	36m up to but not including 52m	9m up to but not including 14m
		E	52m up to but not including 65m	9m up to but not including 14m
		F	65m up to but not including 80m	14m up to but not including 16m

7 AVIATION SECURITY

7.1 Aviation security is an integral part of aerodrome / Aircraft Landing Area planning and operations. Contact should be made with GCAA Aviation Security Affairs Sector for details regarding security requirements.²

8 AERONAUTICAL INFORMATION SERVICE³

8.1 Reference should be made to CAR Part IX.

² GCAA CAR Part VII Aviation Security Regulations

³ UAE AIP: Part 3 Aerodromes (AD 1.4)

8.2 If regular operations are to take place, it is advisable to publicise the location of your Aircraft Landing Area and ensure that your activities are coordinated with other nearby civil and military aviation activity. Only information which can directly be attributed to a responsible source is disseminated.

CHAPTER 3 – PHYSICAL CHARACTERISTICS

1. GENERAL

1.1 The following summarizes the basic requirements for a non-instrument runway. It is the responsibility of the Aircraft Landing Area operator to ascertain whether the Aircraft Landing Area meets the specification for obstacle clearance surfaces upon which these Aerodrome Reference Code Letters are based.

2 DECLARED DISTANCES

2.1 Terrain and obstacles will affect runway design and length but the runway should be of sufficient length and width for the type of aircraft being operated. (Refer to Chapter 2 Table 2.1).

2.2 The declared distances to be calculated for each runway direction comprise: the take-off run available (TORA), take-off distance available (TODA), accelerate-stop distance available (ASDA) and landing distance available (LDA).

2.3 Where a runway has a displaced threshold (for example, due to the obstacle environment), then the LDA will be reduced by the distance the threshold is displaced, as shown in Figure 3-1 (D).

2.4 To aid the selection of Aerodrome Reference Code and Declared Distances, refer to Appendix A.

Figure 3-1 Illustrations of Declared Distances

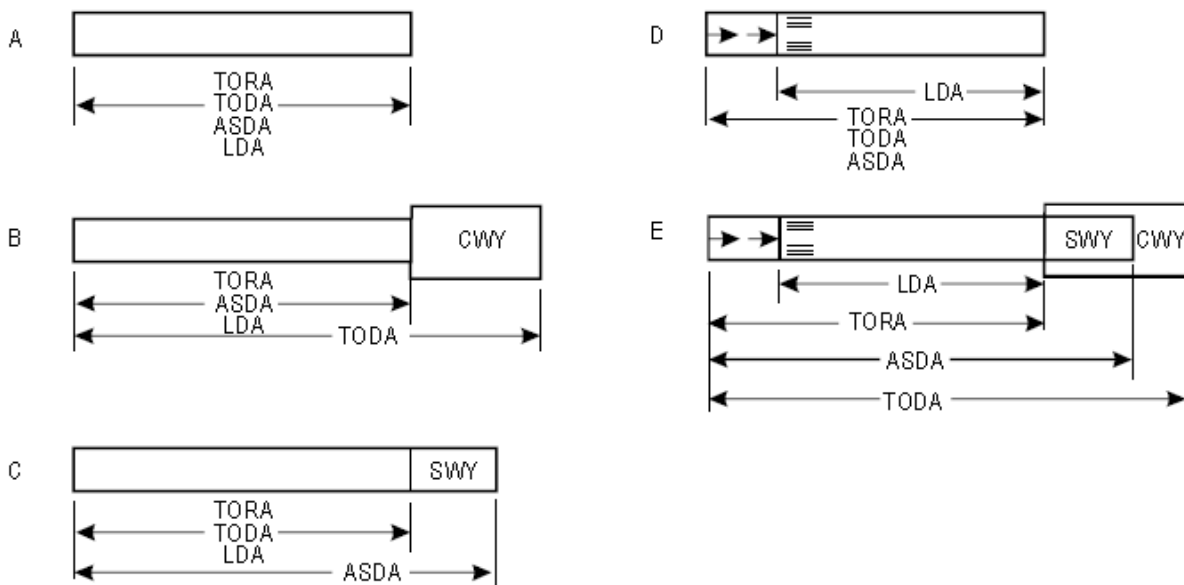

Note. — All declared distances are illustrated for operations from left to right.

3 RUNWAY

3.1 Consideration should be given to the slopes on runways and friction characteristics; details can be referred to in CAR Part IX.

3.2 The surface of the movement area should be inspected at least once on each day the Aircraft Landing Area is available for operations (before flying commences), and at other times when conditions or events could affect aviation safety. (Refer to Civil Aviation Advisory Publication (CAAP) 36 – Runway and Movement Area Inspections).

3.3 The surface should be kept free from loose stones, chippings, grit and other debris which might damage an aeroplane or its engines

3.4 Width - a minimum runway width should be available with reference to the Aerodrome Code Number.

Table 3-1 Runway Widths

Code Number	Code Letter					
	A	B	C	D	E	F
1	18 m	18 m	23 m	---	---	---
2	23 m	23 m	30 m	---	---	---
3	30 m	30 m	30 m	45 m	---	---
4	---	---	45 m	45 m	45 m	60 m

3.5 Length - A runway length equal to or greater than that specified in the aeroplane's Approved Flight Manual (AFM) or approved performance charts for the prevailing conditions should be required. Both take-off and landing requirements need to be considered for both directions.

4 RUNWAY STRIP

Table 3-2 Runway Strip (meters)

	Non-Instrument Code Number 1	Non-Instrument Code Number 2	Non-Instrument Code Number 3	Non-Instrument Code Number 4
Length (Distance before the threshold and beyond the end of the runway or stopway) :	30	60	60	60
Width (each side of the runway centre-line & extended centre-line) :	30	40	75	75
Longitudinal slope (should not exceed) :	2%	2%	1.75%	1.5%
Transverse slope (should not exceed) :	3%	3%	2.5%	2.5%

4.1 The Graded area is equal to the runway strip. Runway and taxiway edges should be constructed to avoid presenting a vertical face to aircraft wheels in any direction from which

an aircraft is likely to approach. The surface of that portion of a strip that abuts a runway, should be flush with the surface of the runway

4.2 The strength of the runway strip / Graded area should be prepared or constructed as to minimize hazards arising from differences in load-bearing capacity to aeroplanes which the runway is intended to serve in the event of an aeroplane running off the runway.

4.3 Runway End Safety Areas - A runway end safety area should extend from the end of a runway strip to a distance of at least 90 m, but preferably 120 m where the code number is 1 or 2 and 240 m where the code number is 3 or 4. The width should be at least twice that of the associated runway, but preferably equal to that of the graded portion of the associated runway strip.

4.4 This area should provide a cleared and graded area for aeroplanes which the runway is intended to serve in the event of an aeroplane undershooting or overrunning the runway.

5 TAXIWAYS

Table 3-3 Taxiway clearances and dimensions (meters)

	Code Letter A	Code Letter B	Code Letter C	Code Letter D	Code Letter E	Code Letter F
Clearance distance between the outer main wheel of the aeroplane and the edge of the taxiway should be not less than:	1.5	2.25	3 or 4.5*	4.5	4.5	4.5
Width of taxiway (Straight portion):	7.5	10.5	15 or 18*	18 or 23*	23	25
Taxiway Strip from centreline:	16.25	21.5	26	40.5	47.5	57.5
Grading of taxiway strip (central portion):	11	12.5	12.5	19	22	30
Taxiway Longitudinal slopes (should not exceed):	3%	3%	1.5%	1.5%	1.5%	1.5%
Taxiway Transverse slopes (should not exceed):	2%	2%	1.5%	1.5%	1.5%	1.5%
<i>Note 1: Wheel base means the distance from the nose gear to the geometric centre of the main gear. *Refer to CAR Part IX</i>						

5.1 The strength of should be at least equal to that of the runway it serves, due consideration being given to the fact that a taxiway will be subjected to a greater density of traffic and, as a result of slow moving and stationary aeroplanes, to higher stresses than the runway it serves.

5.2 A taxiway strip should extend symmetrically on each side of the centre line of the taxiway throughout the length of the taxiway to at least the distance from the centre line given in Table 3-3. It should be clear of objects which may endanger taxiing aeroplanes.

Table 3-4 Taxiway Minimum Separation Distances (meters)

Code Letter	Distance between taxiway centreline and runway centreline				Taxiway centreline to taxiway centreline	Taxiway centreline to object (Strip)	Taxilane centreline to object (Strip)
	Non-Instrument Code Number 1	Non-Instrument Code Number 2	Non-Instrument Code Number 2	Non-Instrument Code Number 2			
A	37.5	47.5	-	-	23.75	16.25	12
B	42	52	-	-	33.5	21.5	16.5
C	-	-	93	-	44	26	24.5
D	-	-	101	101	66.5	40.5	36
E	-	-	-	107.5	80	47.5	42.5
F	-	-	-	115	97.5	57.5	50.5

6 HOLDING BAYS, RUNWAY HOLDING POSITIONS

6.1 A runway-holding position should be established on the taxiway, at the intersection of a taxiway and a runway; and at an intersection of a runway with another runway when the former runway is part of a standard taxi-route.

Table 3-5 Minimum distances from the runway centreline to a holding bay, runway holding position or road holding position (meters)

Non-Instrument Code Number 1	30
Non-Instrument Code Number 2	40
Non-Instrument Code Number 3	75
Non-Instrument Code Number 4	75

7 APRONS / AIRCRAFT PARKING

7.1 If designated parking areas are provided:

- a) They should not be sited under aircraft flight paths or within the runway strip, and should have barriers and notices warning against unauthorized entry.
- b) Suitable fire extinguishers should be available in areas where aircraft engines are started.
- c) Slope on aprons should not exceed 1%.

- d) The size of the apron depends on a number of factors for example, the size and maneuverability of aircraft, clearance requirements and the type of ingress and egress to the stand. The overall aircraft size dimensions can be used as the starting point in establishing the overall apron area requirement. All other areas needed for clearances, taxiing, servicing, etc., must be determined with regard to this basic aircraft “footprint”.⁴

Table 3-6 Clearance distances between an aircraft using the stand and any adjacent building, aircraft on another stand and other objects (metres)

Code Letter	Clearance
A	3
B	3
C	4.5
D*	7.5
E*	7.5
F*	7.5

*Refer to CAR Part IX

⁴ ICAO Doc 9157 Aerodrome Design Manual (Part 2: Taxiways, Aprons and Holding Bays)

CHAPTER 4 – OBSTACLE RESTRICTION AND REMOVAL

1 INTRODUCTION

1.1 An Aircraft Landing Area may be affected by natural features and man-made constructions inside and outside its boundary. These may result in limitations on the distance available for take-off and landing, and it is for these reasons, certain areas of the local airspace must be regarded as integral parts of the Aircraft Landing Area environment.

1.2 The method of assessing the significance of any existing or proposed object within the Aircraft Landing Area boundary or within its vicinity is to establish defined **obstacle limitation surfaces** particular to a runway and its intended use. The purpose of this Chapter is to define these obstacle limitation surfaces and their characteristics and describe the action to be taken in respect of objects which infringe them.

1.3 A survey using these surfaces should be conducted to aid the assessment of the obstacle environment and to identify any actions that need to be taken to remove any obstacle that infringes these protected slopes.

2 OBSTACLE LIMITATION SURFACES

Figure 4-1 Obstacle Limitation Surface

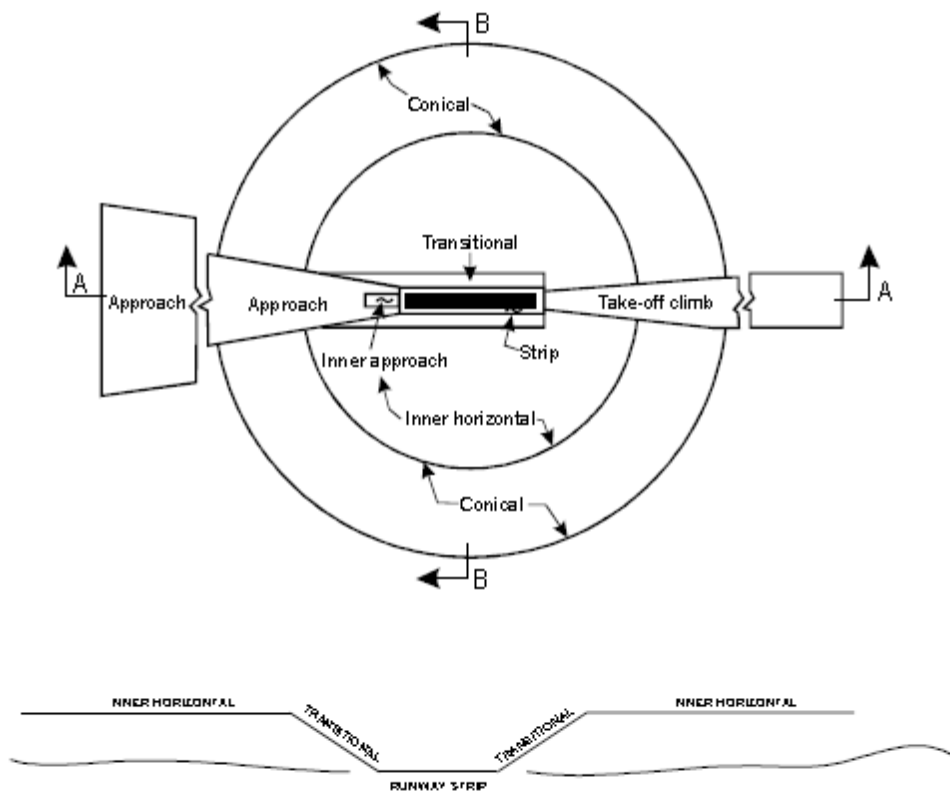

2.1 The following obstacle limitation surfaces should be established for non-instrument approach runways:

Table 4-2 Approach Runways

Obstacle Limitation Surface	Non-Instrument Code Number 1	Non-Instrument Code Number 2	Non-Instrument Code Number 3	Non-Instrument Code Number 4
CONICAL Slope: Height:	5% (1:20) 35m	5% (1:20) 55m	5% (1:20) 75m	5% (1:20) 100m
INNER HORIZONTAL Height: Radius:	45m 2000m	45m 2500m	45m 4000m	45m 4000m
APPROACH Length of inner edge: Distance from threshold: Divergence (each side): Length: Slope:	60m 30m 10% 1600m 5% (1:20)	80m 60m 10% 2500m 4% (1:25)	150m 60m 10% 3000m 3.33% (1:30)	150m 60m 10% 3000m 2.5% (1:40)
TRANSITIONAL Slope:	20% (1:5)	20% (1:5)	14.3% (1:7)	14.3% (1:7)
All dimensions are measured horizontally.				

Figure 4-3 Approach surface non-instrument Code Number 1

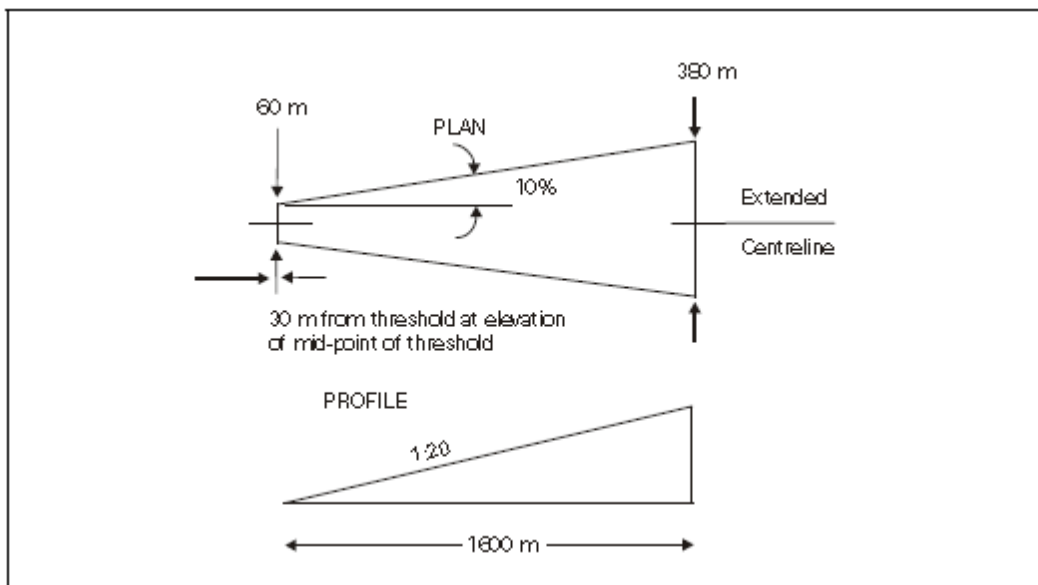
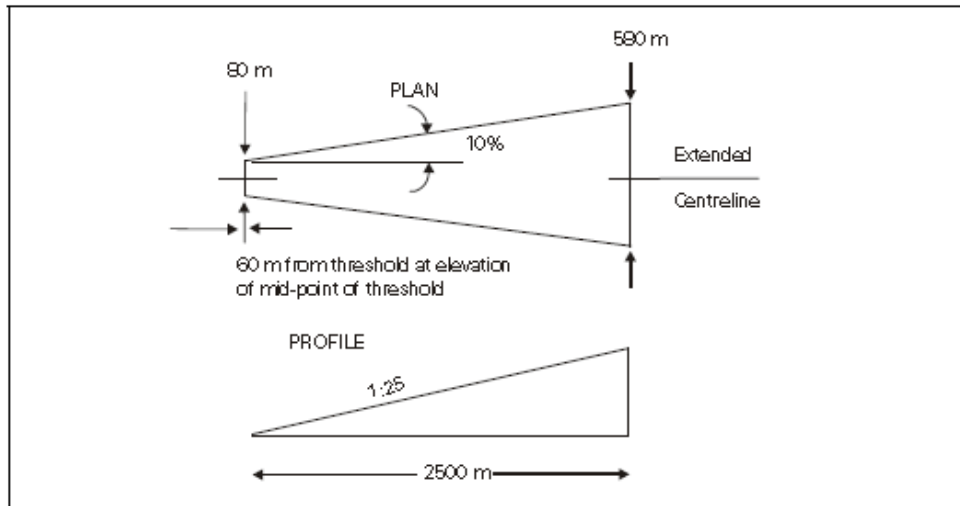

Figure 4-4 Approach surface non-instrument Code Number 2



2.2 The following obstacle limitation surfaces should be established for runways meant for take-off:

Table 4-5 Runways meant for take-off

Obstacle Limitation Surface	Non-Instrument Code Number 1	Non-Instrument Code Number 2	Non-Instrument Code Number 3 or 4
TAKE-OFF CLIMB			
Length of inner edge:	60m	80m	180m
Distance from runway end:	30m	60m	60m
Divergence (each side):	10%	10%	12.5%
Final width:	380m	580m	1200m or 1800m*
Length:	1600m	2500m	15000m
Slope:	5% (1:20)	4% (1:25)	1.6% (1:62.5)*

*Refer to CAR Part IX

Figure 4-6 Take-off climb surface Code Number 1

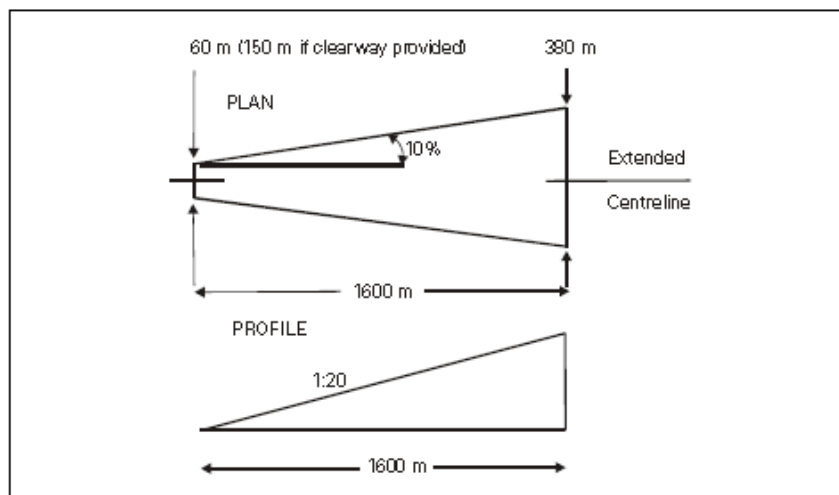
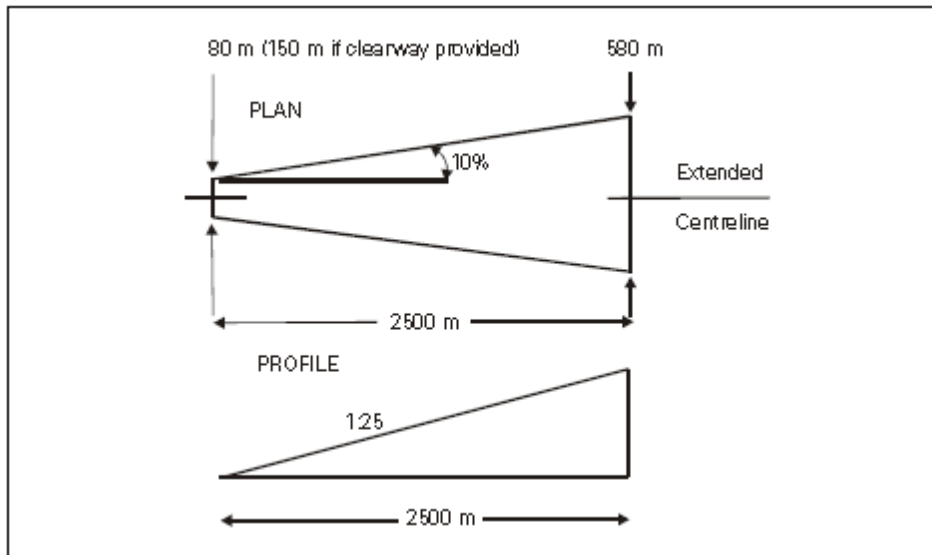

Figure 4-7 Take-off climb surface Code Number 2



3 SAFEGUARDING OF AIRCRAFT LANDING AREAS⁵

3.1 The operator should have procedures in place to monitor the changes in the obstacle environment, marking and lighting and in human activities or land use on the Aircraft Landing Area and the areas around the aerodrome. This may include procedures involving the local municipality, in order to ensure that no proposed structure will affect the operational activity or infringe the Obstacle Limitation Surfaces.

3.2 The limits of the Aircraft Landing Area surroundings that should be monitored by the operator are those relating to the Obstacle Limitation Surfaces and should include the areas that can be visually monitored during the inspections of the manoeuvring area.

3.3 The operator should have procedures to mitigate the risks associated with changes on the Aircraft Landing Area and its surroundings identified with the monitoring procedures.

3.4 The risks caused by human activities and land use which should be assessed and mitigated should include:

- a) obstacles and the possibility of induced turbulence;
- b) the use of hazardous, confusing and misleading lights;
- c) the dazzling caused by large and highly reflective surfaces;
- d) sources of non-visible radiation or the presence of moving or fixed objects which may interfere with, or adversely affect, the performance of aeronautical communications, navigation and surveillance systems;

⁵ Source: EASA

- e) non-aeronautical ground lights near an Aircraft Landing Area which may endanger the safety of aircraft and which should be extinguished, screened or otherwise modified so as to eliminate the source of danger;
- f) the potential of developments or activities which may attract birds or other wildlife.

4 OBSTACLE RESTRICTION AND REMOVAL

4.1 The Aircraft Landing Area operator should ensure that, within the Obstacle Limitation Surfaces, obstacles are restricted and removed as follows:

(1) Objects on runway strips

- (i) An object situated on a runway strip which may endanger aeroplanes should be regarded as an obstacle and should, as far as practicable, be removed.
- (ii) No fixed object, other than visual aids required for air navigation purposes and satisfying the relevant frangibility standards, should be permitted on a runway strip.
- (iii) No mobile object should be permitted on this part of the runway strip during the use of the runway for landing or take-off.

(2) Non-Instrument approach runways

- (i) New objects or extensions of existing objects should not be permitted above an approach surface or a transitional surface.
- (ii) New objects or extensions of existing objects should not be permitted above the conical surface or inner horizontal surface.
- (iii) Existing objects above any of the conical surface, the inner horizontal surface, the approach surface and the transitional surfaces should as far as practicable be removed.

(3) Runways meant for take-off

- (i) New objects or extensions of existing objects should not be permitted above a take-off climb surface.
- (iii) Existing objects that extend above a take-off climb surface should as far as practicable be removed.

(4) Other Objects

Objects which do not project through the approach surface, but which would nevertheless adversely affect the optimum siting or performance of visual or non-visual aids should, as far as practicable, be removed.

(5) Marking and lighting of obstacles

- (i) The Aircraft Landing Area operator should ensure that all obstacles penetrating the obstacle limitation surfaces of an Aircraft Landing Area should be marked

and/or lighted unless such marking or lighting is not required from a safety viewpoint.

- (ii) The Aircraft Landing Area operator should ensure that fixed objects that extend above an obstacle protection surface should be marked and, if the runway is used at night, lighted.

CHAPTER 5 – VISUAL AIDS FOR NAVIGATION

1 INDICATORS, SIGNALS AND MARKINGS

1.1 All signals, signs and markings should be repainted, cleaned or replaced as soon as their conspicuity is degraded.

1.2 Markings and markers provided should be of the specification described in CAR Part IX Appendix 12. For those markings / markers not listed below, reference should be made to CAR Part IX; with reference to the form and proportions of the letters, numbers and symbols of mandatory instruction markings and information markings on a 20 cm grid.

2 MARKINGS

2.1 Runway markings should be white.

- a) A runway designation marking should be provided at the thresholds; the two-digit number should be the whole number nearest the one-tenth of the magnetic North when viewed from the direction of approach.
- b) A runway centre line marking should be located along the centre line of the runway between the runway designation markings. The length of each stripe should be equal to the length of the gap (each being 30m). The width should be 0.30m.
- c) Where a runway threshold is permanently displaced, arrows conforming to App 12 of CAR Part IX should be provided on the portion of the runway before the displaced threshold.
- d) A runway side stripe marking should be provided between the thresholds of a paved runway where there is a lack of contrast between the runway edges and the surrounding terrain. The width should be at least 0.45m.
- e) For unpaved runways, frangible or flush edge markings may be used. The flat rectangular markers should have a minimum size of 1 m by 3 m and should be placed with their long dimension parallel to the runway centre line. The conical markers should have a height not exceeding 50 cm.

2.2 Taxiway markings and aircraft stand markings should be yellow.

- a) Taxiway centre line marking should be provided on taxiways to provide continuous guidance between the runway centre line and aircraft parking areas / stands.
- b) A taxiway centre line marking should be at least 15cm in width.
- c) An unpaved taxiway should be provided, so far as practicable, with the markings prescribed for paved taxiways.
- d) At an intersection of a taxiway with a runway where the taxiway serves as an exit from the runway, the taxiway centreline marking should curve into the runway centreline marking. The taxiway centre line marking should extend parallel to the

runway centreline marking for a distance of at least 30 m beyond the point of tangency.

- e) Taxiway edge markers should be provided on a taxiway where the Code Number is 1 or 2 and where taxiway centreline or edge lights are not provided. Taxiway edge markers should be retroreflective blue, frangible and their height should be sufficiently low to preserve clearance for propellers and for the engine pods of jet aircraft.
- f) Taxiway centreline markers should be provided on a taxiway where the Code Number is 1 or 2 and taxiway centre line or edge lights or taxiway edge markers are not provided.

2.3 Runway-Holding Position Markings should be displayed along a runway-holding position as illustrated in Figure 5-1, (Pattern "A") and should be perpendicular to the runway.

Figure 5-1 Runway – Holding Position Marking: Pattern "A"

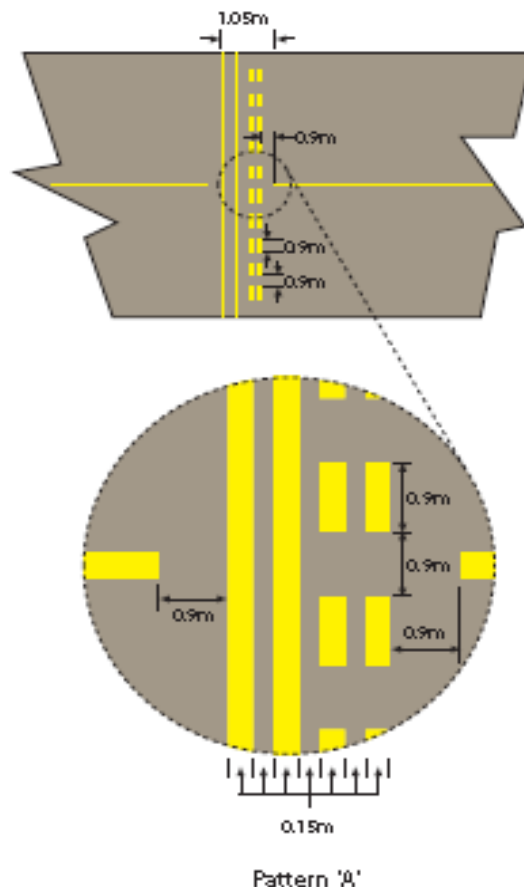

2.4 Apron safety lines should be of a conspicuous colour which should contrast with that used for aircraft stand markings

2.5 A road-holding position marking should be provided at all road entrances to a runway or taxiway and should be displayed as two double white lines.

3 AERONAUTICAL LIGHTS

3.1 Where an Aircraft Landing Area is to be used for night operations, reference should be made to CAR Part IX Appendix 9 Table App 9-1, Aeronautical Ground Lighting Scale 4 (non-instrument).

3.2 The runway should be provided with threshold, edge and end lighting and approach slope guidance ((A)PAPI). For detailed information on (A)PAPI siting and setting angles, refer to CAR Part IX Appendix 9.

3.3 Airfield lighting and approach slope guidance can be permanent or portable.

3.4 Runway edge lighting should be placed along, or within 3 m of, the outside edge of the runway with the lights spaced at intervals of 60 ± 6 m. If circuit training is envisaged, omnidirectional lights should be used.

3.5 Threshold and end lighting should consist of a minimum of six lights evenly spaced at intervals of not more than 9 m across the threshold and runway end respectively.

3.6 It is essential that any approach slope guidance is correctly installed and properly maintained. Owners and operators are encouraged to seek advice from the lighting equipment manufacturers prior to installation.

3.7 Taxiways, if provided, should be identified at least on one edge by reflective markers or on the centre line by the use of lights. If the lighting system does not adequately illuminate apron edges they should be marked in the same manner as taxiways.

3.8 Obstacles should be lit with steady red low-intensity obstruction lights (refer to CAR Part IX, Appendix 13).

3.9 Illuminated wind direction indicators are required for night operations.

4 SIGNS

4.1 Signs should be provided to convey a mandatory instruction, information on a specific location or destination on a movement area or to provide other information. (Refer to CAR Part IX for detailed specifications).

4.2 Signs should be frangible. Those located near a runway or taxiway should be sufficiently low to preserve clearance for propellers and the engine pods of jet aircraft.

Table 5-2 Location distances for taxiing guidance signs including runway exit signs

Code Number	Sign Height (mm)			Perpendicular distance from defined taxiway pavement edge to nearside of sign	Perpendicular distance from defined runway pavement edge to nearside of sign
	Legend (Character)	Face (Minimum)	Installed (Maximum)		
1 or 2	200	400	700	5-11m	3-10m
1 or 2	300	600	900	5-11m	3-10m
3 or 4	300	600	900	11-21m	8-15m
3 or 4	400	800	1100	11-21m	8-15m

4.3 Taxi Guidance Signs are divided into two categories, namely Mandatory Signs and Information Signs.

4.4 Mandatory Signs:

- a) Should display white characters on a red background.
- b) Should be provided to identify a location beyond which an aircraft taxiing or vehicle should not proceed unless authorised.
- c) Should include runway designation signs, runway-holding position signs, road-holding position signs and NO ENTRY signs.
- d) A pattern "A" runway-holding position marking should be supplemented at a taxiway/runway intersection or a runway/runway intersection with a runway designation sign and supplemented with a runway-holding position sign. (Refer to Figure 5.1)

Figure 5-3 Runway-Holding Position



Figure 5-4 Location / Runway Designation (left side)



4.5 Information Signs:

- a) Should be provided where there is an operational need to provide additional guidance to pilots for example, direction or location signs.
- b) At a taxiway intersection, information signs should be located prior to the intersection and in line with the taxiway intersection marking. Where there is no taxiway intersection marking, the signs should be installed at least 40 m from the centre line of the intersecting taxiway.
- c) A runway exit sign should be located prior to the runway exit point in line with a position at least 30 m prior to the point of tangency.
- d) An intersection take-off sign should be located at the left-hand side of the entry taxiway. The distance between the sign and the centre line of the runway should be not less than 45 m
- e) An information sign other than a location sign should consist of an inscription in black on a yellow background.
- f) A location sign should consist of an inscription in yellow on a black background and where it is a stand-alone sign should have a yellow border.

- g) When designating taxiways, the use of the letters I, O or X and the use of words such as inner and outer should be avoided wherever possible to avoid confusion with the numerals 1, 0 and closed marking.

Figure 5-5 Location / Direction



Figure 5-6 Destination



Table 5-7 Character Heights for Mandatory and Information Signs

Code Number	Minimum Character height		
	Mandatory Instruction Sign	Information Sign	
		Runway exit & runway vacated signs	Other signs
1 or 2	300mm	300mm	200mm
3 or 4	400mm	400m	300m

Figure 5-8 Sign Dimensions (Sign with two runway dimensions)

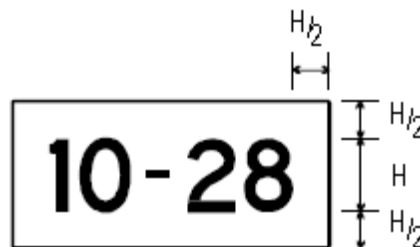

5 WIND DIRECTION INDICATOR

5.1 An Aircraft Landing Area should be equipped with at least one wind direction indicator, clearly visible from the air, and positioned so as to indicate a representative direction and strength should be provided. Avoid locations close to trees or buildings or where terrain may cause an unrepresentative indication, and ensure it will not interfere with aircraft taking-off or landing.

5.2 The colour or colours should be so selected as to make the wind direction indicator clearly visible and understandable from a height of at least 300 m, having regard to background. (Refer to CAR Part IX for further details).

6 SIGNAL AREA

6.1 A signal area need be provided only when it is intended to use visual ground signals to communicate with aircraft in flight. Such signals may be needed when the Aircraft Landing Area does not have a control tower or a flight information service unit, or when the Aircraft

Landing Area is used by aeroplanes not equipped with radio. Visual ground signals may also be useful in the case of failure of two-way radio communication with aircraft.⁶

6.2 The signal area should be located so as to be visible for all angles of azimuth above an angle of 10° above the horizontal when viewed from a height of 300 m. The signal area should be an even horizontal surface at least 9 m square.

6.3 The colour of the signal area should be chosen to contrast with the colours of the signal panels used, and it should be surrounded by a white border not less than 0.3 m wide.

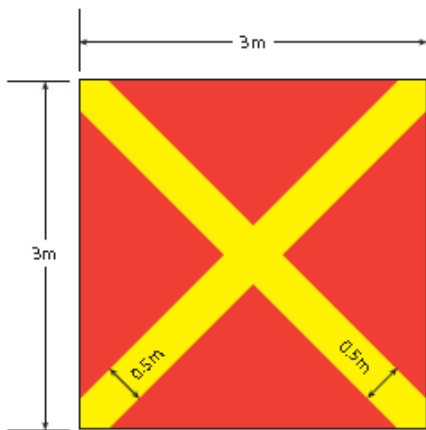

Figure 5-9 Prohibition of landing

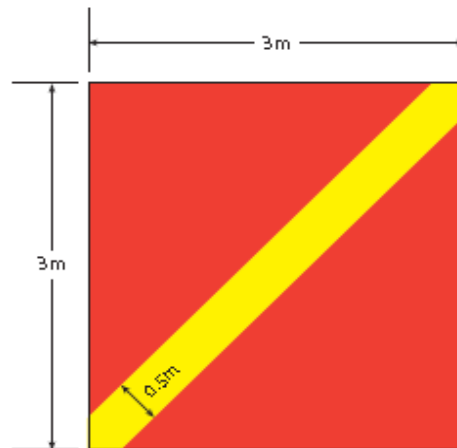

Figure 5-10 Need for special precautions while approaching or landing

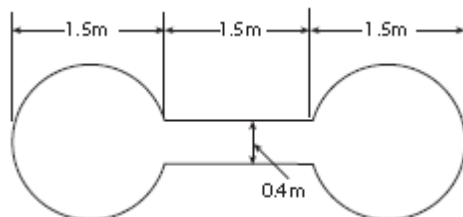

Figure 5-11 Use of runways and taxiways (Aircraft are required to land, take off and taxi on runways and taxiways only).

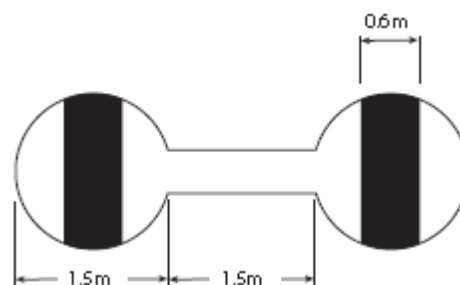

Figure 5-12 Aircraft are required to land and take off on runways only, but other manoeuvres need not be confined to runways and taxiways.

⁶ ICAO Annex 14 Volume 1 & ICAO Aerodrome Design Manual Part 4

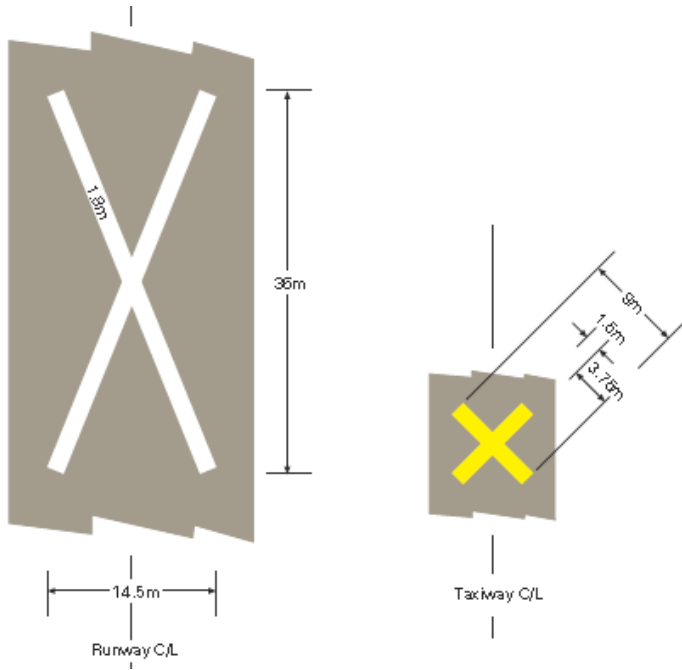

Figure 5-13 Closed runways or taxiways

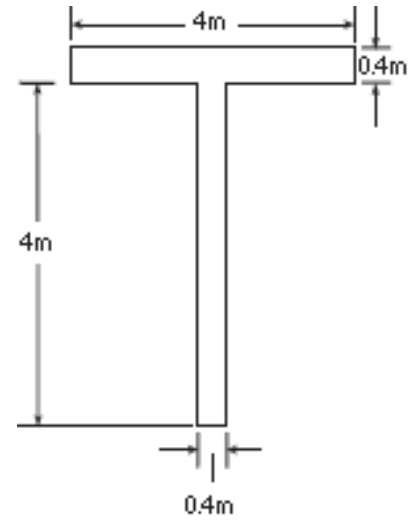

Figure 5-14 Direction for landing or take-off

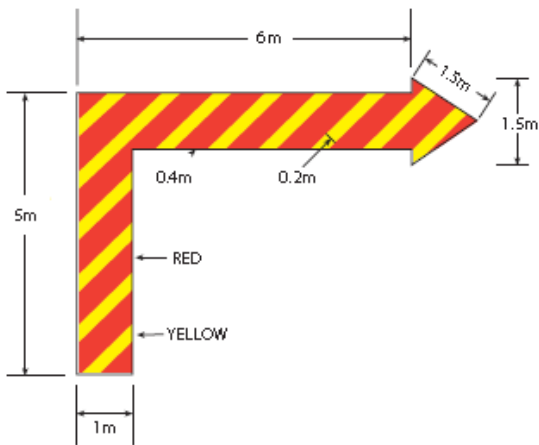

Figure 5-15 Right-hand traffic

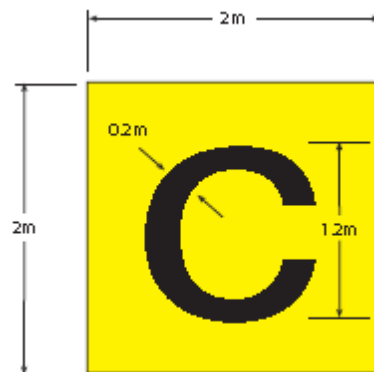

Figure 5-16 Air traffic services reporting office

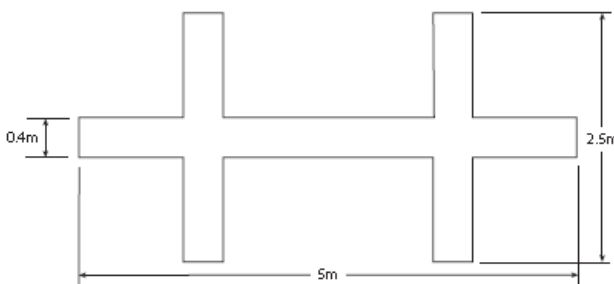

Figure 5-17 Glider flights in operations

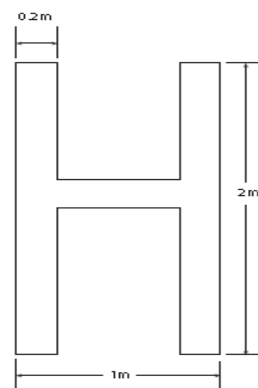

Figure 5-18 Helicopter Landing Area

CHAPTER 6 – AEROPLANE FIRE TEAM

1 PRINCIPLE OBJECTIVE

1.1 The principal objective of an Aeroplane Fire Team is to save lives. For this reason, the provision of means for dealing with an aircraft accident/incident within the Aeroplane landing area provides the greatest opportunity for aircraft rescue.⁷

1.2 Aircraft Rescue: - is defined as actions taken to save or set persons involved in an aircraft accident/incident, support self-evacuation, and to assist the removal of injured / trapped persons.

1.3 The operational objective is to staff the Aeroplane Fire Team Response facility and respond as quickly as possible to any aircraft incident. Trained personnel should be designated to respond and operate the Aerodrome Fire Team Response vehicles and/or equipment whenever flights required to use the aerodrome are taking place.

1.4 A trained Aerodrome Fire Team (AFT) is available to safely respond and operate Fire Extinguisher equipment to control and extinguish any fire, and assist in any rescue and/or evacuation of persons directly affected in any incident/accident, to a place of safety.

1.5 The level of Aeroplane Fire Team that should be provided at an Aeroplane landing area depends upon the size of aircraft expected to use the aerodrome.

1.6 The aerodrome category shall be determined from Table 6-1, and shall be based on the longest aeroplanes normally using the aerodrome and their maximum fuselage width.

Table 6-1

Aircraft Overall Length	Fuselage Width	Number & Types of Extinguishers & Equipment	
Up to but not including 9 m	2 m maximum	2 x 4 kg CO2 or 3 x 9 kg DCP 4 x 9 Litre Foam 4 x 9 Water	Designated Fire Point First Aid Box
Up to but not including 12 m	2 m maximum	3 x 4 kg CO2 or 4 x 9 kg DCP 6 x 9 Litre Foam 6 x 9 Litre Water	Designated Fire Point First Aid box
Special equipment and media should be carried either or by suitable trailer connected to the vehicle with a minimum quantity appropriate to the size and type of aircraft. Full Protective Equipment is essential for all Aerodrome Fire Team personnel.			

1.7 If, after selecting the category appropriate to the longest aeroplanes overall length, that aeroplanes fuselage width is greater than the maximum width in Fuselage Width column,

⁷ CAR PART XI Principal Objective

Table 6-2 for that category, then the category for that aeroplane shall actually be one category higher.

Table 6-2

Aerodrome Emergency Services Category	Aircraft Overall Length	Maximum Fuselage Width
1	0 up to but not including 9m	2m
2	9m up to but not including 12m	2m
3	12m up to but not including 18m	3m
4	18m up to but not including 24m	4m
5	24m up to but not including 28m	4m
6	28m up to but not including 39m	5m
7	39m up to but not including 49m	5m
8	49m up to but not including 61m	7m
9	61m up to but not including 76m	7m
10	76m up to but not including 90m	8m

2 EXTINGUISHING AGENTS

2.1 Determining the appropriate level of fire-fighting and emergency equipment is dependent on the level of operations at the aerodrome.

2.2 Both principal (water and foam) and complimentary agents (CO2; Dry Chemical Powder or a combination of these agents) should normally be provided at a landing area.

2.3 Where different types of extinguishing agents are available for use on an aerodrome, care must be taken to ensure incompatible types are kept apart and stored in accordance with manufacturer’s guidance.

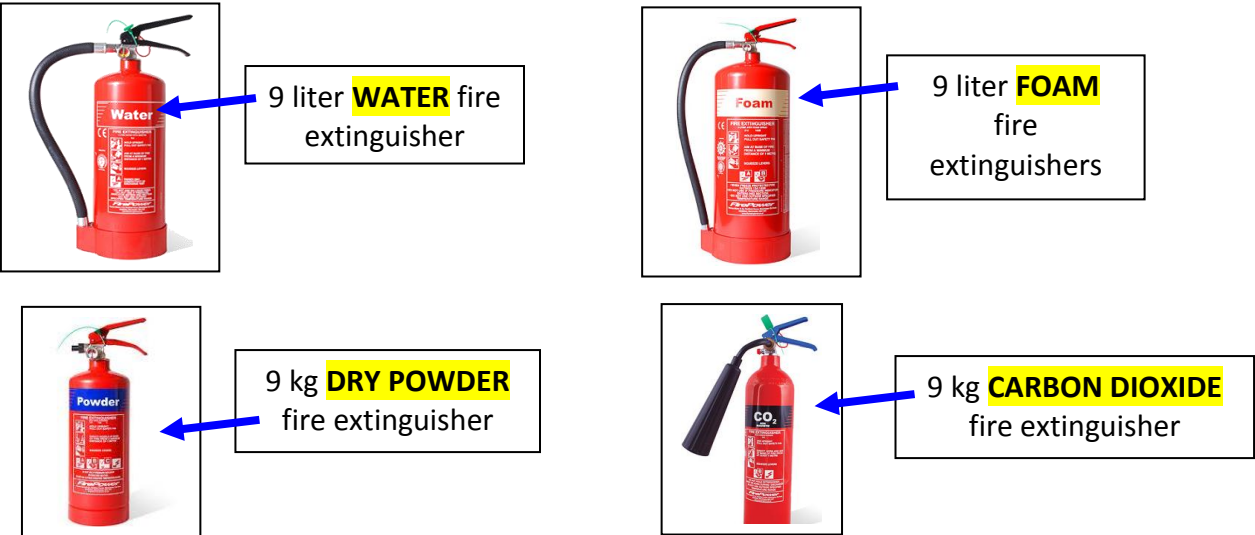

Additional Examples of Extinguishers



2.4 The quantities of water shown in Table 6-3 are based on the average overall length of aeroplanes in a given category. Where operations of an aeroplane larger than the average size are expected, the quantities of water would need to be recalculated. Refer to the ICAO Airport Services Manual Part 1: Rescue and Fire Fighting (Doc 9137), for additional guidance.

Table 6-3

Column 1	Column 2	Column 3		Column 4		Column 5	Column 6
Aerodrome Category	PRINCIPAL AGENTS			Discharge Rate Foam Solution (Lpm)		COMPLEMENTARY AGENTS	Minimum Number of Foam Producing Fire Vehicles
	Water (Litres)	Foam Concentrate (Litres)		LEVEL B 5.5 LPM/m ²	LEVEL C 3.75 LPM/m ²	Dry Chemical Powder (kg)	
		LEVEL B	LEVEL C				
1	230	28	19	230	160	45	See Table 6.1
2	670	82	55	550	360	90	
3	1 200	144	96	900	630	135	1
4	2 400	288	192	1 800	1100	135	1
5	5 400	648	432	3 000	2200	180	1
6	7 900	948	632	4 000	2900	225	2
7	12 100	1452	968	5 300	3800	225	2
8	18 200	2184	1456	7 200	5100	450	3
9	24 300	2916	1944	9 000	6300	450	3
10	32 300	3876	2584	11 200	7900	450	4

2.5 Such fire-fighting equipment should be located close to any aircraft parking and engine start location and clearly identified as a **Designated Fire Point**. It may be advisable to place fire-fighting and rescue equipment on a small trailer and during flights connect the trailer to a vehicle for immediate response to the Designated Fire Point/incident site. *See example below:*

A **Designated Fire Point** provides clearly identified location of extinguishers for immediate access in event of an incident/accident.



2.6 At the start of each initial flight, the aerodrome operator should ensure the appropriate extinguishers are inspected, in position and available for immediate use. All fire-fighting should be tested and inspected at a frequency determined by the manufacture. GCAA CAAP 35 (Inspection and Testing of Fire Service Equipment) provides further guidance.

2.7 Aeroplane Fire Team vehicle and ancillary equipment if the level of aircraft operations requires a more substantive level of service then a vehicle that is mechanically reliable, fit for purpose, and which is capable of accommodating Aeroplane Fire Team personnel should be provided. The vehicle, including any towed equipment, should be capable of traversing the terrain likely to be encountered in response to any incident; all-wheel drive may be necessary. Specified equipment should be carried either on the vehicle or on a suitable trailer connected to the vehicle.

2.8 The following list of firefighting and rescue equipment should be considered by operators. Refer to Table 6-4.

RESCUE EQUIPMENT – Table 6-4		
Adjustable wrench	Flashlights	Ladders/steps access aircraft
Axe, aircraft non-wedging	General purpose line/rope	Personal Protective Clothing
Bolt cropper	General purpose saw	Powered rescue tool
Breathing Masks (filter)	Hacksaw (+ spare blades)	Set Screwdrivers
Crowbar	Harness knife (with sheath)	Side-cutting pliers
Fire resistant blanket	Hook, grab or salving	Tin snips

Minimum quantities of medical equipment resources appropriate to the sizes and types of aircraft should be provided. An assessment of the medical equipment to be provided should be undertaken by the Aerodrome Operator.

3 RESPONSE TIME OBJECTIVE

3.1 The Aeroplane Fire Team should be able to achieve a response time as quickly and as safe as possible to any part of the aeroplane landing area

4 MINIMUM NUMBER OF AEROPLANE FIRE TEAM PERSONNEL

4.1 The minimum number of personnel and level of supervision recommended is detailed in Table 6-5.

Table 6-5	AFT Personnel	AFT Supervision
AEROPLANE LANDING AREA	One (2)	One (1)

4.2 Aeroplane Fire Team should be available whenever flights required to use the aerodrome are taking place. It should be maintained for at least fifteen (15) minutes after the time of departure of any aircraft requiring the use of the Aerodrome landing area or until the aircraft has reached its destination.

5 TRAINING AND DEVELOPMENT

5.1 Aeroplane Fire Team should be provided with sufficient training and be competent in the safe and effective use of resources. See CAR Part XI Appendix 2 for guidance. Table 6-6 provides the minimum training requirements.

Table 6-6

TRAINING SUBJECT AREAS	INITIAL	ON GOING	TRAINING SUBJECT AREAS	INITIAL	ON GOING
AERODROME FAMILIARISATION	✓	✓	BASIC FIRST AID/ CPR	✓	✓
AERODROME/PERSONAL SAFETY	✓	✓	FIRE EXTINGUISHER OPERATIONS	✓	✓
AIRCRAFT FAMILIARISATION	✓	✓	RESCUE TECHNIQUES	✓	✓
VEHICLE DRIVING	✓	✓	EMERGENCY RESPONSE	✓	✓

Equipment and Training records: should be maintained and retained for future reference.

6 EMERGENCY RESPONSE PLANNING

The objective of Emergency Response Planning is to anticipate the effects an emergency might have on life, property, and Landing Area operations, and to prepare a course, or courses, of action to minimize those effects, particularly in respect of saving lives.

6.1 An Aerodrome Response Plan, which forms part of the Aerodrome Manual, should be provided which should include the necessary areas as listed below: include arrangements for alerting the Aerodrome Fire Team facility, for the immediate notification of other key aerodrome personnel and for summoning externally based emergency services.

6.2 Suggested information for emergency services notification:

Type of Emergency	Type of Aircraft
Persons on Board	Location / Landmarks
Call out AFT	Call out Responsible Persons
Call out Civil Defense FIRE: POLICE: HOSPITALS; any other relevant authority	

6.3 Additional guidance on seaplane accidents in the water is outlined in Appendix 6 to the ICAO Airport Services Manual Part 7: Airport Emergency Planning (Doc 9137).

6.4 The Aerodrome Emergency Plan shall provide cooperation and with the Search and Rescue Coordination Centre as is necessary.

CHAPTER 7 – FUEL MANAGEMENT⁸

1 INTRODUCTION

1.1 The Aircraft Landing Area operator should ensure, either by himself or through formal arrangements with third parties, that organisations involved in storing and dispensing of fuel to aircraft, implement procedures to:

- a) maintain the installations and equipment for storing and dispensing the fuel in such condition so as not to render unfit for use in aircraft;
- b) mark such installations and equipment in a manner appropriate to the grade of the fuel;
- c) take fuel samples at appropriate stages during the storing and dispensing of fuel to aircraft, and maintain records of such samples; and
- d) use adequately qualified and trained staff in storing, dispensing and otherwise handling fuel on the Aircraft Landing Area.

2 AEROPLANE REFUELLING

2.1 An aeroplane should not be refuelled when passengers are embarking, on board or disembarking unless it is properly attended by qualified personnel ready to initiate and direct an evacuation of the aeroplane by the most practical and expeditious means available.⁹

2.2 When refuelling with passengers embarking, on board or disembarking, two-way communication should be maintained by the aeroplane's inter-communication system or other suitable means between the ground crew supervising the refueling and the qualified personnel on board the aeroplane.¹⁰

2.3 Operators and fuel companies should be responsible for the observance of safety procedures during the fuelling of aircraft. All personnel working on aprons should, however, be made aware of the major safety precautions and should report any apparent breach to the person in charge of the fuelling operations, (i.e. the fuelling overseer or Acceptance holder). The main points to be observed are:

- a) no smoking or naked lights within the fuelling zone;
- b) auxiliary power units and ground power units should not be started during the fuelling operation;
- c) a clear exit path maintained to and from the aircraft to allow the quick removal of fuelling equipment and persons in an emergency;
- d) aircraft and supply sources should be correctly bonded and the correct earthing procedures employed;
- e) fire extinguishers of a suitable type should be readily available; and

⁸ Source: ICAO Doc 9137 Aerodrome Services Manual: Part 8, EASA and UK CAP 748

⁹ Source: CAR Part IV and ICAO Annex 6

¹⁰ Source: ICAO Annex 6

- f) fuel spillage should be immediately brought to the attention of the fuelling overseer. Detailed instructions should be laid down for dealing with fuel spillage.

2.4 When necessary, aircraft fuelling companies should be given instructions with respect to the acceptable positioning of vehicles relative to the aircraft to ensure that taxiing clearance limits are not infringed.

3 PROCEDURES FOR SAFE HANDLING AND STORAGE OF FUEL

3.1 The Aircraft Landing Area operator should provide quality control and maintenance procedures for preventing the deterioration or contamination of fuel stored in the fuel installation, procedures for the safe delivery into an aircraft of fuel fit for use, and procedures for the retention of records.

3.2 Fuel management procedures should include, but not be limited to, the following:

- a) fuel reception, storage, and quality maintenance;
- b) the assessment of fuel quality;
- c) the safe delivery into an aircraft of fuel fit for the purpose;
- d) the taking and storing of fuel samples;
- e) the onward distribution of fuel;
- f) incident prevention;
- g) incident management;
- h) preventing or minimising electrostatic discharge during the handling of fuel;
- i) handling fuel during extremes of weather e.g. electric storms in the Aircraft Landing Area vicinity or in high ambient temperatures;
- j) the actions to be taken should fuel be found to be contaminated; and
- k) regular and periodic maintenance and cleaning of fuel installations and equipment.

4 RISK EVALUATION: FIRE RISK

4.1 The Aircraft Landing Area operator should consider the risks associated with those stages of the fuel handling and distribution process that relate to personnel for example, passengers and crew, apron staff, and fuelling operatives; to fuel installations and fuel equipment; and in so doing should:

- a) identify the key responsibilities of individuals involved in the management and distribution of fuel;
- b) ensure that all personnel involved in the processes of receiving, storing, and dispensing of fuel are suitably trained or experienced to carry out the associated tasks; and
- c) perform periodic audits of all fuel installations to ensure compliance with the Aerodrome Manual and procedures.

4.2 The Aircraft Landing Area operator should address the fire risk associated with the processes involved in the handling of fuel, taking into account the volatility of the fuels

involved, the method of delivery and the potential for a hazardous fuel/air mixture and a heat/ignition source to be present at the same time.

4.3 The use of any equipment with the potential to create or induce a source of ignition should be identified and excluded from any fuelling zone/area. Equipment maintenance, repairs, and testing procedures, including the operation of switches, radios and other devices, with the potential to create a source of ignition within the Fuelling Zone, should be deferred until fuelling has finished.

4.4 Procedures should be established to prevent fuel ignition from other heat sources for example, aircraft Auxiliary Power Unit exhausts, overheated wheel brakes, jet efflux from other aircraft.

4.5 The Aircraft Landing Area operator should be aware that a spark of sufficient intensity to ignite fuel vapour may be produced by the discharge of electrostatic energy (static) created either from the movement of the fuel in the aircraft tank during the fuelling process, or its accumulation on the surface of aircraft or vehicles. A description of each type together with the practices used to prevent its occurrence is given below.

Surface accumulation: A static charge may be accumulated on the surface of the aircraft or fuelling vehicle, when conditions are favourable. Bonding can eliminate this hazard.

Fuel movement accumulation: A static charge may build up in the fuel during the fuelling operation, and if of sufficiently high potential, it can cause sparking within the aircraft or storage tank. The charge density in the fuel and the possibility of sparks inside the tanks are not affected by bonding. However, the use of static dissipater additives in fuel can contribute materially to reducing the risk involved.

4.6 Bonding connections should be made to designated points or to clean unpainted metal surfaces, and should connect the installation delivering the fuel, with the aircraft or installation receiving the fuel. All connections should be made before filler caps are removed i.e. prior to the start of fuelling, and not broken until fuelling is complete and the filler caps have been replaced where applicable. On no account should either the fuelling vehicle (including hydrant dispenser) or the aircraft be bonded to a fuel hydrant pit. All electrical bonding wires, clips and reels should be checked daily for firm attachment and general condition and weekly for electrical continuity (there should be less than 25 ohms resistance).¹¹

4.7 Hoses (including so called “conductive” hoses) are not considered to be suitable substitutes for dedicated clips and wires designed to provide effective bonding.

4.8 Fuel suppliers should be consulted on whether the fuel being supplied contains a static dissipater additive, and on the adoption of operating procedures and engineering safeguards to minimise the hazards associated with the accumulation of static.

¹¹ Source: Joint Inspection Group (JIG) Aviation Fuel Quality Control and Operating Standards

4.9 When fuelling with turbine fuels not containing a static dissipater, or where wide-cut fuels are involved, a substantial reduction in fuel flow rate is advisable to avoid fuel ignition in the tank due to electrostatic discharge. Wide-cut fuel is considered to be 'involved' when it is being supplied or when it is already present in the aircraft tanks. It is recommended that when wide-cut fuel has been used the next two uplifts of fuel should be treated as though they too were wide-cut.¹²

4.10 When initially filling a filter separator vessel the fuel flow should be regulated to prevent an excessive build-up of static electricity.

4.11 Mixtures of wide-cut and kerosene turbine fuels can result in the air-fuel mixture in the tank being in the combustible range at common ambient temperatures during fuelling.

4.12 The means for alerting the fire service should be readily available. The Aircraft Landing Area operator should ensure that the circumstances under which the fire service would be required for example fuel fire, fuel spill, over-heated wheel brakes, and the means by which it can be alerted are fully understood by those who work on the apron, or in aircraft fuelling or parking areas.

5 RISK EVALUATION: PORTABLE ELECTRONIC DEVICES (PED)

5.1 There are three primary risks associated with the use of PEDs in the vicinity of aircraft: Fire, Distraction, and Aircraft System Interference.

Fire: The risk of a PED creating or inducing a spark of sufficient intensity to ignite fuel vapour released during fuelling is extremely remote under normal circumstances. However, licensees should be aware of the proliferation of below-specification mobile telephone batteries that have the potential to fail dangerously. It is not known whether such a failure would be of sufficient magnitude to ignite a fuel/ air mixture, but licensees should be aware that such a possibility exists. It is recommended that they consider the circumstances under which such an event might occur on the apron, and mitigate the associated risks accordingly.

Distraction: The known potential for a PED user to be distracted presents three associated risks:

- a) physical contact with the aircraft by the distracted PED user could cause damage or injury;
- b) equipment being operated by a distracted PED user could cause damage to an aircraft; and
- c) PED users, distracted while performing essential safety related tasks, could leave those tasks incomplete or unattended.

NOTE - Managers should be aware that the hazards at b) and c) above are associated with actions or inactions by apron staff, and carry the potential for the effect to be concealed until a stage of flight where the safety of the aircraft could be compromised.

¹² CAR Part IV OPS 1

Aircraft System Interference: Reports have been received that the use of PEDs close to modern aircraft can interfere with fuel gauges, some navigation equipment, and can cause spurious fire warnings in cargo/baggage holds. Such interference could contribute to the risks associated with any of the following:

- a) an overweight take-off due to excessive fuel;
- b) a flight with insufficient fuel;
- c) navigational errors; and
- d) a degradation of confidence in the aircraft fire warning system.

5.2 The Aircraft Landing Area operator should prohibit the use of PEDs on the apron area, or should restrict their use to clearly defined and promulgated circumstances that mitigate the risks associated with their use. These mitigations should be considered against the volatility of the fuel type involved, the proximity of vehicle and aircraft vents, the circumstances under which they may be operated, the category of the hazard, and the provision of an alternative non-interfering communication system. Passengers boarding or disembarking the aircraft should be discouraged from using PEDs when outside, but in the vicinity of, the aircraft.

6 DETECTION AND PREVENTION OF FUEL CONTAMINATION

Sampling Checks

6.1 Sampling checks should be made throughout the fuel handling, storage and distribution process to ensure that the fuel is free from water and solid particle contamination, is of the appropriate grade, and is in a state fit for use by aircraft.

6.2 When fuel has been delivered into a fuel installation a settling period should be allowed before a sample is taken. If a fuel sample proves to be unsatisfactory then the sampling procedure should be repeated. If a third sample is necessary and proves to be unsatisfactory, then action should be taken to identify the cause of contamination and no fuel should be dispensed to aircraft from the installation concerned. It would, in this case, be advisable to inform and seek advice from the fuel supplier concerned.

6.3 Samples should be taken and retained for a minimum of seven days:

- a) from fuel on delivery, whether by road tanker, pipeline, or in packages;
- b) from fuel stored in a bulk tank, hydrant system, vehicle or packed stock, each day aircraft refueling takes place; and
- c) whenever laboratory testing is required e.g. when Jet A-1 has been stored and not added to for a period of six months or when aviation gasoline AVGAS has been stored and not added to for a period of three months.

6.4 In addition to when they are required by other processes, fuel samples should be taken at the following times:

- d) immediately before receipt into the fuel installation;
- e) after receipt of fuel into the fuel installation (after settling time);
- f) each day before the first delivery from the fuel installation;

- g) after prolonged heavy rainfall;
- h) after de-fuelling;
- i) after vehicle washing;
- j) immediately prior to fuelling an aircraft.

6.5 Fuel samples from above ground storage tanks and aircraft fuelling vehicles should be drawn from sampling or drain cocks. A “thief-pump” should be used for obtaining samples from buried tanks and barreled supplies.

6.6 All sampling equipment should be kept in a scrupulously clean condition. Clear glass jars with necks and screw caps should be used for sample examination and retention. Prior to a sample being taken, the pipeline should be “flushed” to an extent that will remove residual fuel from within it. Managers should seek the advice of the fuel supplier on the quantity required to achieve a satisfactory check. Fuel that is not to be retained and is found to be free of contamination can be returned to the tank.

6.7 Samples of fuel taken should be clearly labelled, and retained as evidence that the fuel stored in the installation is fit for use in aircraft. They will be of particular value as evidence following an accident occurring to an aircraft that had received fuel from the installation.

6.8 If samples are taken on occasions other than that shown in paragraph 6.4 above they should be drawn into similar containers. Where fuel is drawn into buckets or other metal containers e.g. for flushing, they should be manufactured from stainless steel, and they should be bonded to the fuel line by cable and clip prior to and during the process.

6.9 All retained samples should be kept cool and stored out of daylight and be labeled with the following information:

- a) grade of fuel;
- b) reason for sample;
- c) date and time of sample;
- d) place taken;
- e) name of sampling person.

6.10 It should be noted that the use of equipment for example, tanks, drums, filter systems and hoses intended for substances other than aviation fuels may increase the risk of contamination by water, solid particles or chemical deterioration.

6.11 All fuel equipment and fuel installations should be fully segregated from other products. Different grades of fuels should also be segregated and ideally installations should have separate delivery and suction lines.

6.12 To identify the grade of fuel they contain, all tanks and pipelines should be labeled and colour-coded in accordance with codes of practice promulgated by those organisations referred to in paragraph 7.

6.13 As an additional measure to avoid fuelling errors at delivery, hoses or pipes should be marked with the appropriate grade markings or painted with a band of the appropriate primary grade indicator colour as close as practicable to the delivery nozzle, but not on the

nozzle itself. Only a material that will not flake or separate from the nozzle whilst in general use, for example, a securely attached plastic sleeve or ring should be applied to the delivery nozzle.

6.14 A change of fuel grade in storage tanks can pose a risk of contamination of the new grade by residues of the previous fuel stored and therefore, where possible, such changes should be avoided. If this is not practicable, it is recommended that guidance information should be obtained from the fuel supplier concerned or from the organisations referred to in paragraph 7.

Visual Examination and Testing for Contamination

6.15 Fuel should be considered unfit for use in aircraft if a visual examination shows any of the following:

- a) more than a trace of sediment;
- b) globules of water;
- c) cloudiness;
- d) a positive reaction to water-finding paste, paper or a chemical detector.

6.16 The following should serve as a guide to the visual assessment of fuels:

- a) Colour. AVGAS is available in red, blue and green, while Jet A-1 turbine fuel is undyed and can vary in appearance between the colour of clear water to straw yellow. The terms 'clear' and 'bright' are independent of the natural colour of the fuel. 'Clear' refers to the absence of sediment or emulsion. 'Bright' refers to the sparkling appearance of fuel free from cloud or haze.
- b) Turbine fuels should be checked using a chemical water detector. The presence of free or suspended water is indicated by a distinct change in the colour of the paste, paper or detector element. When a single, clear, apparently colourless liquid is drawn from a container believed to contain aviation gasoline, visual testing alone is inadequate to determine whether it is pure fuel or pure water. Testing by hydrometer or water detecting paste, paper or detector element is required.
- c) Undissolved water (free water) will appear as droplets on the sides or as bulk water on the bottom of the sample vessel. Free water will separate quickly from AVGAS. When the fuel has water in suspension the sample will appear hazy or cloudy.

6.17 Solid particle contamination generally consists of small amounts of rust, sand, dust, scale etc. suspended in the fuel or settled out on the bottom of the sample vessel.

6.18 Water-finding paste applied to the end of a dipstick or dip tape should be used for direct checking of turbine fuel in bulk storage, or barrels, and may be used similarly for AVGAS. Fresh paste should be used for each check and the dipstick should be allowed to rest on the bottom of the container for up to but no longer than 10 seconds.

Record Keeping

6.19 Written records should be kept of:

- a) all deliveries into fuel installations. These records should include the grade and quantity of the fuel, the delivery date, and should include copies of release notes or certificates of conformity.
- b) the particulars of the maintenance, including any associated rectification, and cleaning of the fuel installation. These should include details of:
 - i) inspections and tests;
 - ii) pressure, purging, equipment, and filter checks; and
 - iii) hose inspections.
- c) the particulars of fuel samples taken and the results of tests of those samples.
- d) all barrel deliveries, and of the associated decanting and dispensing of fuel, and of sampling checks.

6.20 Written records of de-fuelling operations should include details of:

- a) the aircraft registration;
- b) the date of de-fuelling;
- c) the results of sampling checks;
- d) the quantity and grade of fuel drawn; and
- e) the disposal of the fuel drawn.

6.21 The records referred to above should be kept for a minimum of twelve months. They should include details of consequential action where a defect or deficiency has been revealed.

7 TECHNICAL SPECIFICATIONS

7.1 The technical aspects or specifications of fuel installation construction are covered by codes of practice supported by the petroleum industry including:

- a) installation and vehicle manufacturers;
- b) Joint Inspection Group (JIG), www.jointinspectiongroup.org
- c) International Air Transport Association (IATA), www.iata.org

CHAPTER 8 – AIRCRAFT LANDING AREA OPERATIONS

1. AERODROME MANUAL

1.1 Applicants for Aircraft Landing Area Acceptance should submit an Aerodrome Manual in accordance with CAR Part IX Chapter 3. The Aerodrome Manual Checklist (available on the GCAA website at www.gcaa.gov.ae) should be used as a framework for the production of the Aerodrome Manual. (Refer to Aerodrome Manual template)

1.2 The Manual should contain all the relevant information with regard to an efficient management structure and a systematic approach to operations. It should describe the services, facilities, all operating procedures and any restrictions on the Aircraft Landing Area availability, applicable to the level of service offered.

1.3 For many small Aircraft Landing Areas the Aerodrome Manual can be both simple and brief as long as it covers procedures essential for satisfactory day-to-day operations, commensurate with the level of service.

2 SAFETY MANAGEMENT SYSTEMS (SMS)

2.1 An effective Safety Management System is requirement for an Aircraft Landing Area Acceptance. (This will be a component of the Aerodrome Manual).

2.2 An effective Safety Management System (SMS) is an organised approach to managing safety, including the necessary organisational structures, accountabilities, policies and procedures, and forms the primary safety oversight covering the way an Aircraft Landing Area operator manages safety. It also provides an identifiable and easily audited systematic control of the management of safety at an Aircraft Landing Area. By applying lessons learned, an SMS should aim to make measurable improvements to the overall level of safety.

2.3 The GCAA has aligned SMS with the ICAO SMS Framework. This Framework consists of a number of key components further subdivided into 12 elements and where possible, Aircraft Landing Area operators should include or refer to each of the elements within their SMS.

Table 8-1 Framework for SMS

<i>Components</i>	<i>Elements</i>
1. Safety policy and objectives	a) Management commitment and responsibility b) Safety accountabilities c) Appointment of key safety personnel d) Coordination of emergency response planning e) SMS documentation
2. Safety risk management	a) Hazard identification b) Risk assessment and mitigation
3. Safety assurance	a) Safety performance monitoring and measurement b) The management of change c) Continuous improvement of the SMS
4. Safety promotion	a) Training and education b) Safety communication

2.4 Aircraft Landing Areas vary in size and the level of complexity of the services provided and therefore the level of detail of your SMS should reflect this. However, it should still be possible for all Aircraft Landing Areas to implement all of the 12 elements of the framework to some degree.

2.5 Further guidance on SMS can be found with CAR Part IX and CAAP 50 available on the GCAA website at www.gcaa.gov.ae.

3 MANDATORY REPORTING

3.1 In most cases the obligation to report is on the holder of an Aircraft Landing Area Acceptance, which in most cases is the organisation, but in some cases can be a single person. (Refer to CAAP 22: Safety Incident Reporting).

3.2 The mandatory reporting requirement is supported by the GCAA's "Reporting of Safety Incident" (ROSI) system is available on GCAA website's (www.gcaa.gov.ae).

3.3 Guidance on the GCAA's voluntary reporting is found in CAAP 57 – Voluntary Occurrence Reporting System.

4 WILDLIFE HAZARD MANAGEMENT

4.1 Wildlife, particularly bird activity is a hazard at all Aircraft Landing Areas therefore awareness of the hazard must be high and procedures should be in place should wildlife control activity be necessary.

4.2 Reasonable attempts should be made to remove birds or features on the Aircraft Landing Area that may attract birds or wildlife. Wherever practicable, this should include the area in the vicinity of the Aircraft Landing Area to prevent bird flight paths across it and its approach and departure routes.

4.3 As part of the Safety Management System, a Wildlife Hazard Management Plan should be developed. (Refer to CAR Part IX, Chapter 4).

5 FOREIGN OBJECT DEBRIS (FOD)

5.1 Aircraft Landing Area operators should develop and implement specific procedures for the elimination of the risk of FOD. They should also ensure that any third party can demonstrate a satisfactory level of FOD awareness and that their working procedures do not increase the likelihood of FOD. (Refer to CAAP - 43 Foreign Object Debris).

6 LOW VISIBILITY OPERATIONS

6.1 Aircraft operations during reduced visibility or low cloud conditions present additional hazards to the aircraft and to other users. It is the responsibility of the holder of the Aircraft Landing Area Acceptance to develop procedures to close the Aircraft Landing Area during such conditions.

7 NIGHT USE

Where the landing area is required for the take-off and landing of aircraft at night, systems of lighting appropriate to the Category of runway in use as described in CAR Part IX, Appendix 9 should be in operation at all times when aircraft are taking-off or landing at the Aircraft Landing Area at night.

APPENDIX A: AERODROME REFERENCE CODE & AERODROME DATA

To aid the process for an assessment of an Aircraft Landing Area Acceptance, complete the following table with reference to the aeroplane performance characteristics and dimensions:

Largest aircraft type for which the Aircraft Landing Area is intended.	
Code Number corresponding to the highest value of the aeroplane reference field length of the aeroplanes for which the runway is intended.	
Code Letter corresponds to the greatest wingspan, or the greatest outer main gear wheel span, whichever gives the more demanding code letter of the aeroplanes for which the facility is intended.	
Declared Distances:	
a) Take-off run available (TORA)	
b) Take-off distance available (TODA)	
c) Accelerate-stop distance available (ASDA)	
d) Landing distance available (LDA)	
Runway Length	
Runway width	
Runway Designator (and bearing)	
Obstacle Limitation Surfaces: dimensions and slopes: a) Transitional Surface b) Approach Surface <i>Inner Edge:</i> <i>Distance from Threshold:</i> <i>Divergence (each side):</i> <i>Length:</i> <i>Slope:</i> c) Inner Horizontal Surface <i>Height:</i> <i>Radius:</i> d) Conical Surface <i>Inner Edge:</i> <i>Distance from runway end:</i> <i>Divergence (each side):</i> <i>Length:</i> <i>Slope:</i> e) Take-Off Climb Surface <i>Inner Edge:</i> <i>Distance from runway end:</i> <i>Divergence (each side):</i> <i>Length:</i> <i>Slope:</i>	

APPENDIX B: REQUIREMENTS FOR AERODROME CERTIFICATION OR AIRCRAFT LANDING AREA ACCEPTANCE

This Table should be used to evaluate if operations require an aerodrome to be certificated under the definition of “Air Service” including other aerodromes which provide facilities for operations using instrument approach or departure procedure; or for those requiring an Aircraft Landing Area Acceptance (not Air Service operations and non-instrument runways)

NOTE 1: The categorisation of flights for Public Transport may differ for Flight Crew Licensing, Flight Operations and Airworthiness. Applicable Regulation should therefore apply. The issue of an Aerodrome Certificate or Aircraft Landing Area Acceptance, does not constitute an “approval” from Flight Operations Department, with reference to CAR Part IV-OPS 3.

NOTE 2: The GCAA may approve the certification of aerodromes or provide a Landing Area Acceptance (whichever is deemed appropriate), once the criteria have been met; however the responsibility for the maintenance and condition of the landing area, the facilities and for obstacle control, remains with the Certificate / Acceptance Holder.

Type of Operation		Status	Aerodrome Certification or Aircraft Landing Area Acceptance
1	Payment is made for the carriage of passengers, mail or cargo (other than crew).	Air Service	Aerodrome Certificate
2	Passengers, mail and cargo are carried for no payment, by an AOC holder.	Air Service	Aerodrome Certificate
Phased Process for Aircraft Landing Area Acceptance – Initial Self-Assessment			
3	Payment is only for the pilot; for example, this allows a private owner to pay a flying instructor for a flying lesson in the owner’s aircraft.	Private Operator	Aircraft Landing Area Acceptance
4	Flying Displays and Races Direct costs (i.e. fuel) for no profit is permitted, but excludes payment to the pilot.	Private Operator	Aircraft Landing Area Acceptance
5	Cost Sharing Provided that the only payment is a contribution to the direct costs of the flight otherwise payable by the pilot in command.	Private Operator	Aircraft Landing Area Acceptance
6	Parachuting Note: Approval required in accordance with GCAA CAR Part IV Special Purpose Operations: Section C, Parachuting Operations.	CAR Part IV OPS 3, Sections C	Aircraft Landing Area Acceptance

7	Flying Schools Note: Approval required in accordance with GCAA CAR Part IV Special Purpose Operations: Section A, Approved Flying Schools.	CAR Part IV OPS 3, Sections A	Aircraft Landing Area Acceptance
8	Hospitals / Clinics Operations to facilities will be required to apply special procedures.	Public Service	Helicopter Landing Area Acceptance
Other Operations			
9	Police / SAR Certification or acceptance will not apply to landing areas used solely for the purpose of operating police or SAR aircraft.	-	Not required
10	Off-Shore Helideck Operations Dedicated operations to off-shore helideck sites.	-	Acceptance - Oil and Gas Companies