

الهيئة العامة للطيران المدني
GENERAL CIVIL AVIATION AUTHORITY



United Arab Emirates

Air Accident Investigation Sector

Accident

- Preliminary Report -

AAIS Case N° AIFN/0005/2021

Emergency Landing after Engine Failure during Approach

Operator:	Aerosparx Ltd
Make and Model:	Grob G109B
Nationality and Registration:	United Kingdom, G-OSOX
Place of Occurrence:	Skydive Dubai Airfield, Dubai
State of Occurrence:	The United Arab Emirates
Date of Occurrence:	26 March 2021



Accident Brief

AAIS Report No.:	AIFN/0005/2021
Operator:	Aerosparx Ltd
Aircraft Type and Registration:	Grob G109B, G-OSOX
Manufacture Serial Number:	6253
Number and Type of Engines:	One, Grob 2500 E1 piston engine
Date and Time:	26 March 2021, 1530 local time
Location:	Approximately 400 meters inbound runway 17, Skydive Dubai Airfield, Dubai, the United Arab Emirates
Type of Flight:	Private
Persons Onboard:	Two
Injuries:	None

Investigation Objective

This investigation is conducted pursuant to the United Arab Emirates Federal Act 20 of 1991, promulgating the *Civil Aviation Law*, Chapter VII - *Aircraft Accidents*, Article 48. It is in compliance with the *Air Accident and Incident Investigation Regulation (AAIR)*, in conformity with *Annex 13 to the Convention on International Civil Aviation* and in adherence to the *Air Accident and Incident Investigation Manual*.

The sole objective of this investigation is to prevent aircraft accidents and incidents. It is not the intent of this activity to apportion blame or liability.

This Preliminary Report is adapted from the Final Report format contained in Annex 13 to serve the purpose of this investigation. The information contained in this Report is derived from the data collected during the initial investigation of the Accident.

The Final Report may contain amended information when new evidence becomes available during the ongoing investigation.

Investigation Process

The occurrence involved a Grob G109B aircraft, registered as G-OSOX, and was notified to the Air Accident Investigation Sector of the United Arab Emirates (AAIS) by phone call to the Duty Investigator Hotline Number +971 50 641 4667.

An investigation team was formed in line with ICAO Annex 13 obligations of the United Arab Emirates, being the State of the Occurrence.

After the initial on-site Investigation phase, the occurrence was classified as 'accident' due to substantial damage to the aircraft.

The AAIS formed investigation team and appointed an investigator-in-charge. The German Bundesstelle fuer Flugunfalluntersuchung (BFU), being the authority of the State of



aircraft and Engine Manufacture, Design and Certification, and the British Air Accidents Investigation Branch (AAIB), being the authority of the State of Registry, were notified of the accident. Accredited representatives were assigned and assisted by advisers from the European Union Aviation Safety Agency (EASA). The AAIS is leading the investigation and will issue a Final Report when the investigation is completed.

This Preliminary Report is publicly available at:

<http://www.gcaa.gov.ae/en/epublication/pages/investigationReport.aspx>

Notes:

- ¹ Whenever the following words are mentioned in this Report with the first letter capitalized, it shall mean:
 - (Accident) – this investigated accident
 - (Aircraft) – the aircraft involved in this accident
 - (Investigation) – the investigation into this accident
 - (Operator) – Aerosparx Ltd
 - (Pilot) – the pilot of the accident flight
 - (Report) – this Preliminary Report.
- ² Unless otherwise mentioned, all times in this Report are local time of the United Arab Emirates (UTC plus 4 hours).
- ³ Photos and figures used in the text of this Report are taken from different sources and are adjusted from the original for the sole purpose to improve clarity of the Report. Modifications to images used in this Report are limited to cropping, magnification, file compression, or enhancement of color, brightness, contrast or insertion of text boxes, arrows or lines.



Abbreviations and Definitions

AAIS	Air Accident Investigation Sector of the United Arab Emirates
AIFN	Accident/incident file number
CAVOK	Ceiling and visibility ok (METAR information)
GCAA	General Civil Aviation Authority of the United Arab Emirates
ICAO	International Civil Aviation Organization
LT	Local time
NOSIG	No significant change (METAR information)
PPL (A)	Private Pilot License (Aircraft)
QNH	Setting on altimeter to indicate altitude above mean sea level
RPM	Revolutions per minute
UAE	The United Arab Emirates
UTC	Coordinated universal time
VHF	Very high frequency



CONTENTS

Accident Brief.....	ii
Investigation Objective.....	ii
Investigation Process.....	ii
Abbreviations and Definitions.....	iv
1. Factual Information.....	7
1.1 History of the Flight.....	7
1.2 Injuries to Persons.....	7
1.3 Damage to Aircraft.....	7
1.4 Other Damage.....	8
1.5 Personnel Information.....	8
1.6 Aircraft Information.....	9
1.6.1 Aircraft data.....	9
1.6.2 Engine data.....	10
1.6.3 Propeller assembly data.....	10
1.6.4 Propeller Pitch Mechanism.....	11
1.7 Meteorological Information.....	12
1.8 Aids to Navigation.....	12
1.9 Communications.....	12
1.10 Aerodrome Landing Site Information.....	12
1.11 Flight Recorders.....	12
1.12 Wreckage and Impact Information.....	12
1.13 Medical and Pathological Information.....	13
1.14 Fire.....	13
1.15 Survival Aspects.....	13
1.16 Tests and Researches.....	13
1.16.1 Propeller pitch assembly examination.....	13
1.17 Organisational and Management Information.....	13
1.17.1 Flight Manual - IV.4. Other emergencies - e) Emergency landing.....	13
1.18 Additional Information.....	14



1.19 Useful or Effective Investigation Techniques	14
2. Ongoing Investigation Activities.....	15
3. Safety Concerns and Actions	15

List of figures

- Figure 1. Aircraft flight path
- Figure 2. Damage to Aircraft
- Figure 3. Grob G109B Aircraft
- Figure 4. Propeller control on center console
- Figure 5. Propeller control mechanism
- Figure 6. Aircraft location
- Figure 7. Aircraft damage

List of tables

- Table 1. Pilot information
- Table 2. Aircraft data
- Table 3. Engine information
- Table 4. Propeller assembly information

1. Factual Information

1.1 History of the Flight

On 26 March 2021 at 1520 local time (LT), a Grob G109B Aircraft, registered as G-OSOX, departed the Skydive Dubai airfield with a Pilot and a passenger onboard for a private flight in the local area, in formation¹ with a leading Grob G109B aircraft. The flight followed a previous private 10-minute formation flight in the Margham area.

At 1530 LT, the Aircraft was on the left base to runway 17 of the Skydive Dubai airfield at an altitude of approximately 500 feet, when, during the propeller pitch change for landing, the engine stalled and shut down. The Pilot attempted to restart the engine without success. He stated that he noticed that the airbrakes were partially deployed, which he immediately retracted. He also noticed that the propeller had stopped in the 'feather' pitch position.

At this point, the Aircraft was at the end of the left base and the Pilot noticed an asphalt road leading towards the airfield on the left. However, a fence separated the road from runway 17 and he decided to turn right, into the wind, where the road continued in a long straight direction.

During the steep right-turn, the right wing touched the road and fractured. The Aircraft touched down, turned right and slid across the asphalt road into the sand on the other side and came to rest. (Figure 1)

The Pilot and the passenger opened both cockpit doors and exited the Aircraft without assistance.

The leading aircraft landed on runway 17 uneventfully.

1.2 Injuries to Persons

The two occupants were not injured as a result of the Accident.

1.3 Damage to Aircraft

The Aircraft was severely damaged as a result of the ground impact.



Figure 1. Aircraft flight direction on left base to runway 17

¹ Eurocontrol ATM Lexicon: Formation Flight is a flight consisting of more than one aircraft which, by prior arrangement between the pilots, operates as a single aircraft with regard to navigation and position reporting, as well as clearances issued by ATC.

The right wing fractured and separated approximately 190 cm from the wing tip, the left main landing gear separated from the fuselage, the propeller spinner was dented, and the fuselage and engine cowling exhibited several areas of impact damage. (Figure 2)



Figure 2. Damage to Aircraft

1.4 Other Damage

There was no other damage to property or to the environment.

1.5 Personnel Information

Table 1 illustrates the Pilot information current at the time of the Accident and available at the time of the Preliminary Report.

Table 1. Pilot information	
Age	54
Type of license	PPL(A)
Valid to	30 April 2022
Rating	Single Engine, Touring Motor Glider, Instrument Rating
Total flying time (hours)	1,759
Total on this type (hours)	235
Total last 90 days (hours)	9
Total last 7 days (hours)	9
Total last 24 hours (hours)	1:36



Last proficiency check	To be determined
Medical class	2
Valid to	1 August 2021
Medical limitation	VNL ²

1.6 Aircraft Information

The Grob G109B is a two-seat motor glider with a T-type stabilizer, constructed from glass-fiber and carbon-fiber materials. The seats are configured side-by-side.

The landing gear consists of two main wheels, fitted with fairings, and a tail wheel. The G109B has a wingspan of 17.4 meters, a length of 8.1 meters and a height of 1.7 meters. The maximum gross weight is 850 kg. (Figure 3)

The Grob 109B is fitted with Grob 2500 four-cylinder engine. The two-bladed propeller assembly includes a pitch control mechanism.

The fuel tank with a capacity of 100 liters is located in the fuselage behind the wing spar connection unit.

G-OSOX had been modified for 'Display purposes'. These modifications included the installations of light emitting diodes (LED) lights, pyrotechnics, and smoke systems. These modifications and limited aerobatic maneuvers were approved by the European Union Aviation Safety Agency (EASA).

1.6.1 Aircraft data

Table 2 illustrates general Aircraft data as of the date of the Accident and available at the time of the Preliminary Report.

Table 2. Aircraft data	
Manufacturer:	Burkhart Grob Luft-und Raumfahrt GmbH & Co KG
Model:	G109B
Manufacture serial number:	6253
Year of manufacture:	1984
Nationality and registration mark:	United Kingdom, G-OSOX
Name of the Owner:	Aerosparx Ltd
Name of the Operator:	Aerosparx Ltd
Certificate of Airworthiness	
Number:	TE070457/997/002
Issue date:	20 August 2020
Valid to:	29 July 2021

² VNL: Have correction available for defective near vision and carry spare set of spectacles.



Certificate of Registration		
Number:		G-OSOXR1
Issue date:		8 April 2019
Valid to:		Open, unlimited
Total time hours since new (hours):		To be determined
Total cycles since new:		To be determined
Last major inspection and date:		To be determined
Total time since last inspection (hours):		To be determined
Total cycles since last inspection:		To be determined

1.6.2 Engine data

Table 3 illustrates engine data as of the date of the Accident and available at the time of the Preliminary Report.

Table 3. Engine data	
Engine manufacturer:	Burkhardt Grob Luft-und Raumfahrt GmbH & Co KG
Model:	Grob 2500 E1
Serial number:	211
Date installed:	To be determined
Total time since new (hours):	To be determined
Total cycles since new:	To be determined
Last major inspection and date:	To be determined
Total time since last major inspection (hours):	To be determined
Total cycles since last major inspection:	To be determined

1.6.3 Propeller assembly data

Table 4 illustrates propeller assembly data as of the date of the Accident and available at the time of the Preliminary Report.

Table 4. Propeller assembly data	
Propeller assembly manufacturer:	Hoffmann Propeller GmbH & Co KG
Model:	HO-V62-R
Serial number:	A1139P
Date installed:	To be determined

Total time since new (hours):	To be determined
Total cycles since new:	To be determined
Last major inspection and date:	To be determined
Total time since last major inspection (hours):	To be determined
Total cycles since last major inspection :	To be determined

1.6.4 Propeller Pitch Mechanism

The G109B two-bladed propeller is powered directly by the Grob 2500 piston engine. The propeller pitch mechanism consists of three pitch settings.

A 'Prop control knob' (handle) is located on the center console and is used to change between 'fine' and 'coarse' propeller pitch. The 'fine' pitch setting allows the engine to turn at high RPM and is normally used for takeoff and climb. This setting is also used for landing in preparation for a go-around. The 'coarse' pitch setting is used for cruise flight. The change between 'fine' and 'coarse' pitch occurs while the engine is running. (Figures 4 and 5)

The 'feather' setting aligns the propellers into the air stream to minimize drag during gliding flight. The 'feather' selection requires the engine to be switched off first and is made by pulling and turning the 'Prop feather handle', located above the 'prop control knob'. Turning the 'Prop feather handle' will apply the propeller brake to avoid wind-milling.



Figure 4. Propeller control on center console

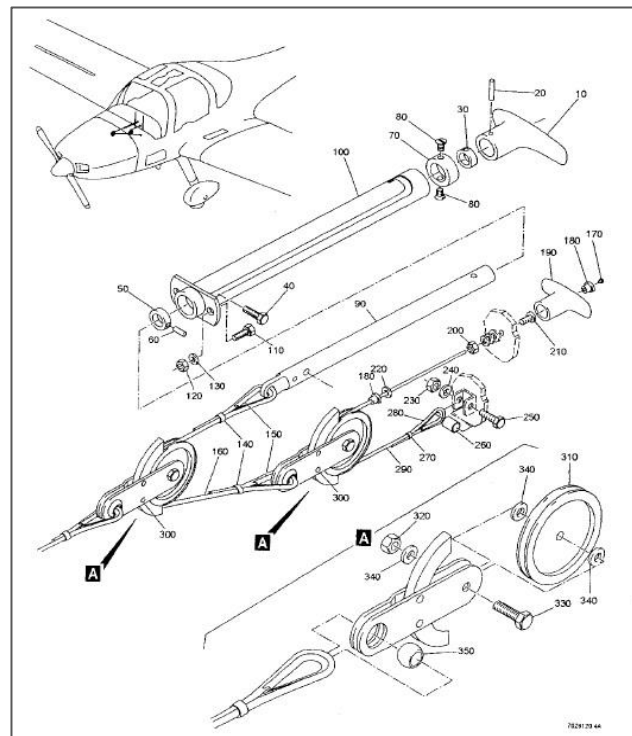

Figure 5. Propeller control mechanism [Source: Grob GmbH]



1.7 Meteorological Information

The meteorological conditions at the time of the Accident were normal with ceiling and visibility OK (CAVOK). The METAR from Dubai International Airport, at a distance of 45 kilometers from Skydive Dubai Airfield, reported the QNH as 1011 Hectopascal. The wind was recorded with a speed of 11 knots from a direction of 330 degrees.

The METAR for the period 1100 to 1130 at Dubai International Airport read:

METAR OMDB 261100Z 33011KT CAVOK 35/11 Q1011 NOSIG
METAR OMDB 261130Z 33011KT CAVOK 35/09 Q1011 NOSIG

The nearest weather station at Margham, a distance of approximately 8 kilometers to the Accident site, recorded wind from 305 degrees with 9 knots, a temperature of 37.6 degrees Celsius, and an air pressure of 1009 Hectopascal.

1.8 Aids to Navigation

Aids to navigation will be discussed in the Final Report.

1.9 Communications

The communication between the formation lead pilot and Pilot of the Accident Aircraft and to air traffic control was made via the VHF radio. Communication between the Pilot and the passenger occurred verbally.

Communications will be further discussed in the Final Report.

1.10 Aerodrome Landing Site Information

Aerodrome information will be further discussed in the Final Report.

1.11 Flight Recorders

The Aircraft was not fitted with a flight data recorder or cockpit voice recorder, and was not required to be fitted with recorders as per the current requirements of the Civil Aviation Authority of the United Kingdom.

1.12 Wreckage and Impact Information

After the Aircraft made a right-turn into the wind, the right wing impacted the asphalt road. The Aircraft impacted the asphalt road and slid sideways across, until it came to rest in the sand. (Figure 6)

The left main landing gear strut detached from the fuselage, and the right wing fractured approximately 190 cm from the wingtip. Damage was also identified on the lower fuselage and the engine cowling and the propeller spinner. The propeller was found in 'feather' pitch position. (Figure 7)



Figure 6. Aircraft location



Figure 7. Aircraft damage

1.13 Medical and Pathological Information

Post-Accident blood tests did not reveal psychoactive materials that could have degraded the Pilot performance.

1.14 Fire

There was no evidence of pre-or post-impact fire.

1.15 Survival Aspects

Survival aspects will be discussed in the Final Report.

1.16 Tests and Researches

1.16.1 Propeller pitch assembly examination

The propeller assembly, consisting of both propellers and the pitch mechanism, were secured and will be sent to the manufacturer for examination in the presence of the accredited representative to the Investigation.

The results will be discussed in the Final Report.

1.17 Organisational and Management Information

1.17.1 *Flight Manual - IV.4. Other emergencies - e) Emergency landing*

The *flight manual (FM)* provided the following emergency landing guidance:

"From sufficient height choose useable field. Watch the wind. Approach to the desired landing site must be executed carefully and precisely. Flare and touchdown smoothly at minimum speed. Prior to touchdown pull stick full aft and brake moderately.



The above mentioned is valid for dead engine and engine failure.

...”

Further organizational factors will be discussed in the Final Report

1.18 Additional Information

The Final Report will include the necessary additional information.

1.19 Useful or Effective Investigation Techniques

The Investigation is conducted in accordance with the *Civil Aviation Law and Air Accident and Incident Investigation Regulation (AAIR)* of the United Arab Emirates, and adherence with the AAIS-approved policies and procedures, and conformance with the Standards and Recommended Practices of *Annex 13* to the Chicago Convention.



2. Ongoing Investigation Activities

The Investigation is ongoing and will include further examination and analysis of:

- Propeller assembly failure cause and history
- Propeller assembly maintenance and reliability
- Other relevant Aircraft systems
- Emergency landing procedures and training
- Any other safety aspects that may arise during the course of this Investigation.

The Investigation will conduct an in-depth analysis of:

- Human factors
- Organisational factors.

3. Safety Concerns and Actions

Safety concerns and actions taken by the parties will be discussed in the Final Report.

This Preliminary Report is issued by:

**Air Accident Investigation Sector
General Civil Aviation Authority
The United Arab Emirates**

e-mail: aai@gcaa.gov.ae
www.gcaa.gov.ae